

INSTALLATION INSTRUCTIONS

IMPORTANT: READ BEFORE INSTALLING FIXTURE.
 RETAIN FOR FUTURE REFERENCE.



SAFETY: This fixture must be wired in accordance with the National Electrical Code and applicable local codes and ordinances. Proper grounding is required to insure personal safety. Carefully observe grounding procedure under installation section.

WARNING: Make certain power is OFF before starting installation or attempting any maintenance. Risk of fire/electric shock. If not qualified, consult an electrician.

- **RISK OF ELECTRIC SHOCK**—Disconnect power at fuse or circuit breaker before installing or servicing.
- **RISK OF BURN**—Disconnect power and allow fixture to cool before servicing.
- **RISK OF PERSONAL INJURY**— Fixture may become damaged and/or unstable if not installed properly. Tighten all fixture components to their recommended torque values. Do not lift pole into place by securing lifting device to lighting fixture or mounting arm.

WARNING: Make certain power is OFF before starting installation or attempting any maintenance.

TOOLS REQUIRED: Ratchet, 9/16" socket, flat blade screw driver, electrical wiring tools.

INSTALLATION

STEP 1. With housing lying on a smooth, soft surface open the access door by releasing the latch. Door may be removed by opening approximately 130° and lifting off the hinge **FIG. 1**.

STEP 2. Bird guard is provided pre-cut to accommodate 1-1/2" diameter (nominal) mounting arms. When using larger diameter mounting arms remove the punch out section of the bird guard.

STEP 3. Using a 9/16" socket, loosen the two or optional four pipe clamp mounting bolts enough to allow mounting arm (not included) to slide onto leveling steps. **FIG. 2**

STEP 4. Close access door. Lift the housing into place, re-open access door, and position end of mounting arm onto leveling steps so that housing is level. Care must be taken so arm does not inadvertently strike internal components. To avoid potential damage to fixture, ensure housing is level both front to back and side to side by placing level on flat surface on top of the housing.

STEP 5. Using a 9/16" socket tighten the two or optional four pipe clamp mounting bolts to 16-18 ft-lbs.

WIRING

STEP 1. Pull service wires through mounting arm and into housing approximately 10".

- STEP 2.**
- Three-terminal block (2-wire service): Connect line service lead to terminal that is connected to black factory-installed wire. Connect neutral service wire to terminal that is connected to white factory-installed wire.
 - Three-terminal block (3-wire service, 2 lines, 1 ground): Connect 1 line service lead to terminal that is connected to black factory-installed wire. Connect other line service lead to terminal that is connected to white factory-installed wire. Connect ground service lead to terminal that is connected to green factory-installed wire.
 - Three-terminal block (3-wire service, 1 line, 1 neutral, 1 ground): Connect line service lead to terminal that is connected to black factory-installed wire. Connect neutral service wire to terminal that is connected to white factory-installed wire. Connect ground service wire to terminal that is connected to green factory-installed wire.

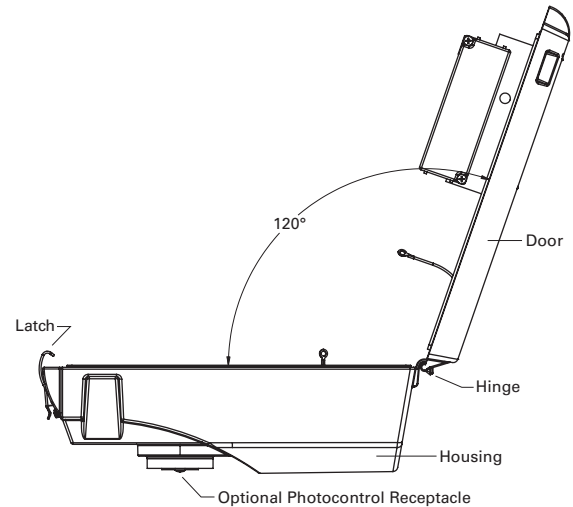

FIG. 1

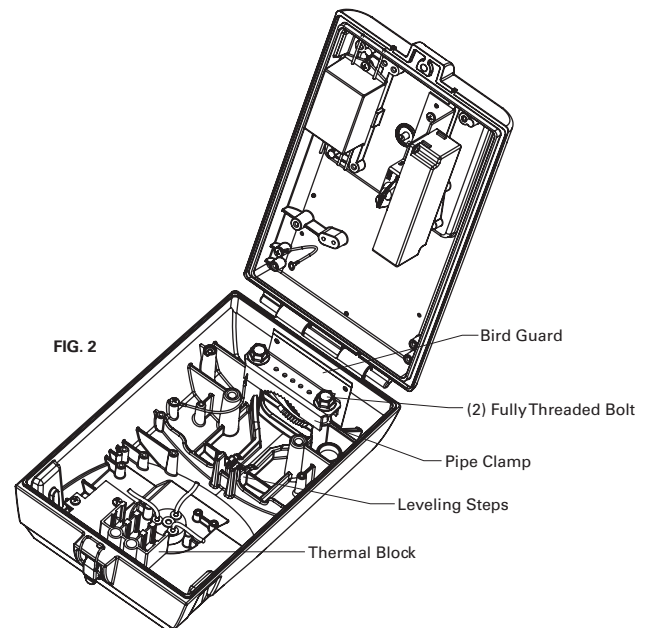

FIG. 2

—CONTINUED

These instructions do not claim to cover all details or variations in the equipment, procedure, or process described, nor to provide directions for meeting every possible contingency during installation, operation or maintenance. When additional information is desired to satisfy a problem not covered sufficiently for user's purpose, please contact your nearest representative. **NOTE:** Specifications and dimensions subject to change without notice.

INSTALLATION INSTRUCTIONS

IMPORTANT: READ BEFORE INSTALLING FIXTURE.
RETAIN FOR FUTURE REFERENCE.

WARNING: Make certain power is OFF before starting installation or attempting any maintenance.

- d. No terminal block (3-wire service, 2 lines, 1 ground): Connect 1 line service lead to black factory-installed wire. Connect other line service lead to white factory-installed wire. Connect ground service lead to green factory-installed wire.
- e. No terminal block (3-wire service, 1 line, 1 neutral, 1 ground): Connect line service lead to black factory-installed wire. Connect neutral service wire to white factory-installed wire. Connect ground service wire green factory-installed wire.

NOTE: SEE WIRING DIAGRAM FOR ADDITIONAL WIRING DETAILS.

STEP 3. Position and secure all wires away from all other electrical components (drivers, terminal blocks).

STEP 4. Close access door and secure latch.

PHOTOCONTROL (IF EQUIPPED)

STEP 1. Using a flat blade screw driver, loosen the two flathead screws to allow rotation of the receptacle.

STEP 2. Insert screwdriver into center slot and rotate receptacle until indicator arrow points north or desired direction.

STEP 3. Tighten screws.

STEP 4. Insert the photoelectric control (or shorting cap) into receptacle and twist into locked position.

NOTE: THE PHOTOCONTROL MUST CONTAIN A SOFT, RESILIENT GASKET FASTENED TO THE BOTTOM SURFACE TO ASSURE A PROPER WEATHER SEAL BETWEEN THE CONTROL AND THE RECEPTACLE.

MAINTENANCE

NOTE: A regular maintenance schedule should be followed to retain optimal light output and thermal performance.

Optical lens cleaning should be performed with a clean dry cloth to remove any dust or other contaminants. Additional cleaning can be performed with non-abrasive acrylic cleanser.

Remove any dirt, leaves or other foreign debris from the housing and fins.
Clean water may be used to flush the fins.

—CONTINUED

These instructions do not claim to cover all details or variations in the equipment, procedure, or process described, nor to provide directions for meeting every possible contingency during installation, operation or maintenance. When additional information is desired to satisfy a problem not covered sufficiently for user's purpose, please contact your nearest representative. **NOTE:** Specifications and dimensions subject to change without notice.

INSTALLATION INSTRUCTIONS

IMPORTANT: READ BEFORE INSTALLING FIXTURE.
 RETAIN FOR FUTURE REFERENCE.

WARNING: Make certain power is OFF before starting installation or attempting any maintenance.

PHOTOCONTROL (IF EQUIPPED)

- STEP 1.** Using a flat blade screw driver, loosen the two flathead screws to allow rotation of the receptacle.
- STEP 2.** Insert screwdriver into center slot and rotate receptacle until indicator arrow points north or desired direction.
- STEP 3.** Tighten screws.
- STEP 4.** Insert the photoelectric control (or shorting cap) into receptacle and twist into locked position.

NOTE: THE PHOTOCONTROL MUST CONTAIN A SOFT, RESILIENT GASKET FASTENED TO THE BOTTOM SURFACE TO ASSURE A PROPER WEATHER SEAL BETWEEN THE CONTROL AND THE RECEPTACLE.

MAINTENANCE

NOTE: A REGULAR MAINTENANCE SCHEDULE SHOULD BE FOLLOWED TO RETAIN OPTIMAL LIGHT OUTPUT AND THERMAL PERFORMANCE.

Optical lens cleaning should be performed with a clean dry cloth to remove any dust or other contaminants. Additional cleaning can be performed with non-abrasive acrylic cleanser.

Remove any dirt, leaves or other foreign debris from the housing and fins. Clean water may be used to flush the fins.

PIPE BRACKET INSTALLATION FIG. 3

TOOLS REQUIRED: 11/16" open wrench, drill.

- STEP 1.** Establish height and location for pipe bracket and luminaire.
- STEP 2.** Drill an 11/16" diameter hole through the pole.
- STEP 3.** Insert thru-bolt through the pole, place square washer and nut on threaded end of thru-bolt.
- STEP 4.** Slide slotted portion of the upper bracket behind the head of the thru-bolt, tighten nut to draw bracket against pole.
- STEP 5.** Drive lag screws through the two holes in the lower bracket and tighten lug screws and thru-bolt with wrench.
- STEP 6.** A ground lug may be included with pipe bracket. To install, insert carriage bolt through square hole in the upper bracket.
- STEP 7.** Attach ground wire around bolt, assemble washer and nut and tighten with wrench.

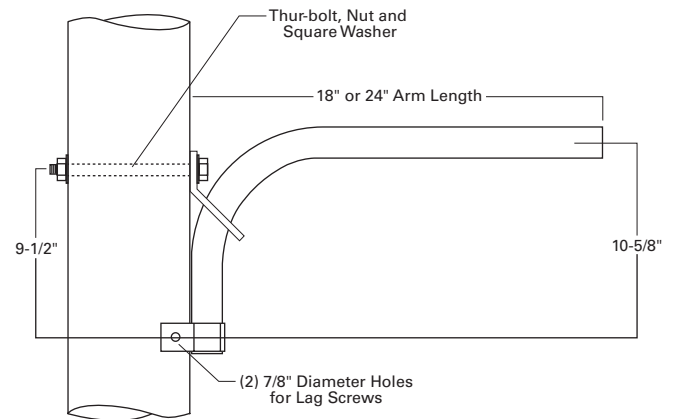

FIG. 3

—CONTINUED

These instructions do not claim to cover all details or variations in the equipment, procedure, or process described, nor to provide directions for meeting every possible contingency during installation, operation or maintenance. When additional information is desired to satisfy a problem not covered sufficiently for user's purpose, please contact your nearest representative. **NOTE:** Specifications and dimensions subject to change without notice.

INSTALLATION INSTRUCTIONS

IMPORTANT: READ BEFORE INSTALLING FIXTURE.
 RETAIN FOR FUTURE REFERENCE.

WARNING: Make certain power is OFF before starting installation or attempting any maintenance.

ARM INSTALLATION (SQUARE POLE) FIG. 4

TOOLS REQUIRED: 1/2" open wrench, Phillips screw driver.

- STEP 1.** Insert nut plate into pole aligning holes on nut plate with mounting holes on the pole.
- STEP 2.** Insert threaded rods through top and bottom holes and screw them into nut plate.
- STEP 3.** Pull wires through center hole of back up plate and center hole of pole.
- STEP 4.** Make electrical connections between wires from pole and wires from the fixture.
- STEP 5.** Align top and bottom holes on the arm to slide over threaded rods. Arm should be flush to the surface of the pole.
- STEP 6.** Push washers over the threaded rods and screw on nuts.
- STEP 7.** Using 1/2" open wrench tighten nuts.
- STEP 8.** Pass cover plate over arm. Align set screw holes on the cover and the arm and tighten set screw.

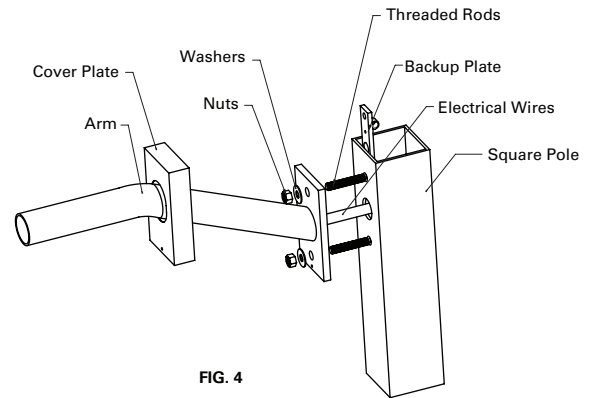

FIG. 4

ARM INSTALLATION (ROUND POLE) FIG. 5

TOOLS REQUIRED: 1/2" open wrench, Phillips screw driver.

- STEP 1.** Insert nut plate into pole aligning holes on nut plate with mounting holes on the pole.
- STEP 2.** Insert threaded rods through top and bottom holes and screw them into nut plate.
- STEP 3.** With the rounded end of the adapter facing the pole, align the holes on the adapter with mounting holes on the pole. Push adapter over threaded rods.
- STEP 4.** Pull wires through center holes nut plate, pole and adapter and make wiring connections.
- STEP 5.** Align top and bottom holes on the arm to slide over threaded rods. arm should be flush with the flat surface of adapter.
- STEP 6.** Push washers over the threaded rods and screw on nuts.
- STEP 7.** Using 1/2" open wrench tighten nuts.
- STEP 8.** Pass cover plate over arm. Align set screw holes on the cover and the arm and tighten set screw.

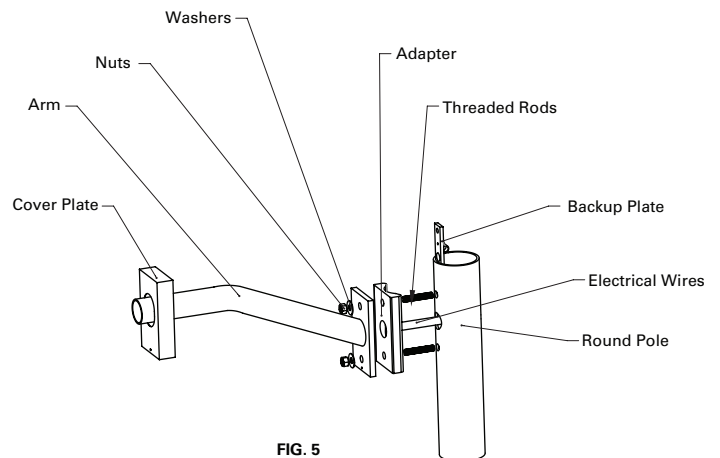

FIG. 5

These instructions do not claim to cover all details or variations in the equipment, procedure, or process described, nor to provide directions for meeting every possible contingency during installation, operation or maintenance. When additional information is desired to satisfy a problem not covered sufficiently for user's purpose, please contact your nearest representative. **NOTE:** Specifications and dimensions subject to change without notice.