

DESCRIPTION

Specification grade 71 watt MR16 downlight pinhole fixture. The 50° cutoff to lamp and lamp image provides a glare free, smooth distribution of light. For use with all halogen MR16 lamps in either open or cover glass varieties. Units small size is ideal for tight construction areas. Insulation must be kept 3" away from sides and top of fixture. **Optical element can be changed after installation to provide a variety of distributions. e.g. into an Adjustable**

SPECIFICATION FEATURES

A...Finish

.040 thick aluminum spun parabolic interior reflector in Black Alzak® finish. Die-cast 1.25" occulus with knife edge produces dark aperture. Occulus with either flat black or white finish. No occulus in "LARGE version".

B...Flange

Die-cast flange with matte white, clear coat, satin aluminum or polished aluminum finish. Die-cast flanges are easily removed for field painting. Elements are keyed for proper insertion.

C...Lens

Soft focus lens standard in platform for smooth beam patterns. Pinhole element includes a clear lens to allow maximum output if desired. Up to two filter media can be used which are retained during relamping.

D...Attachment

Positive torsion springs pull flange tight to ceiling. Mechanical light trap eliminates spill light at edge of flange or reflector.

E...Socket

GX5.3 base for Bi-pin MR16 lamps. Fixed socket height ensures consistent lamp position and back light shield keeps interior of fixture dark.

F...Transformer

Truvolt™ toroidal transformer with dual-output taps for proper 12.0V operation and quiet operation when dimmed. Dimmer tap compensates for inherent voltage loss from dimmers, resulting in 30% more lumens than traditional laminated transformers. Toroidal design, with 90% or greater efficiency, features a rolled one-piece continuous core of M3 grade grain oriented silicon steel complete with an integral thermal to protect against overheating. For dimming, use dimmers rated for electromagnetic transformers.

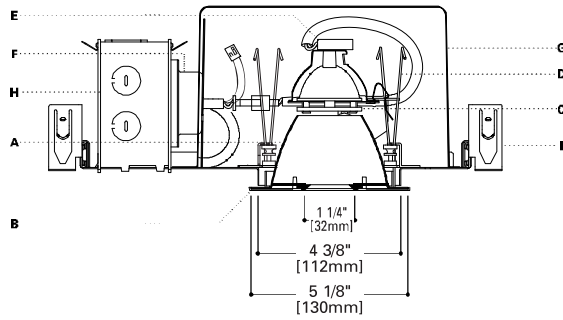

Transformer is warranted for 5 years and is serviceable from below ceiling.

Note: If a dimming system is operated for construction lighting in its "shunt" mode, i.e. bypassing the dimmer modules, for an extended period of time, fixtures with the dual-tap toroidal transformer should be operated on the "Switched Fixture" output until the dimmers are in use. Operating fixtures on the "Dimmed Fixture" output with a full 120v input for an extended period will overdrive the lamp and cause shortened lamp life.

G...Frame/Housing

Hot dipped galvanized 20 gauge steel frame with built in 1/2 inch plaster lip. Gunsights allow for consistent alignment. Matte black housing interior.

H...Junction Box

18 cubic inches, listed for 4#12 AWG or 6#14 AWG 90 C additional feed through conductors, has three 1/2 inch pryouts.

I...Bar Hangers

No Flex® bar hangers with positive locking, for use with wood, engineered wood and steel frame joists spaced up to 24" O.C. ship with platform. For use in T-bar ceilings order accessory MBCLP clips. Nailless barb and locator lip provide consistent installation height.

Codes

Thermally protected, IP labeled. Unit is airtight and exchanges less than 2.0 CFM with the plenum at a pressure of 75 pascals. Insulation must be kept three inches away from fixture sides and none on top as to entrap heat.

Labels

UL and cUL listed, standard damp label, IBEW union made.

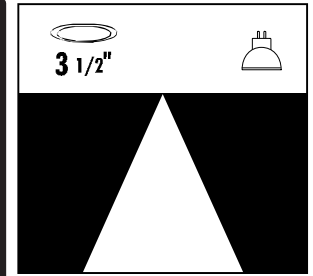

PN3MR E3DNPIN

71 W MR 16

3" DOWNLIGHT
PINHOLE

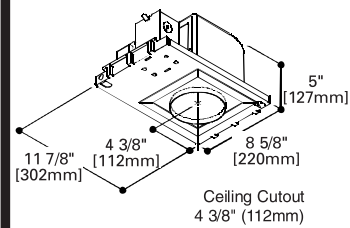

Energy Data

120V Input		
Lamp Watts	Input Watts	Operating Current
20	23	.19
35	41	.34
37	42	.35
42	47	.39
50	57	.48
65	70	.58
71	77	.64
75	81	.68

PINHOLE ELEMENT VARIETIES (PLAN VIEW)

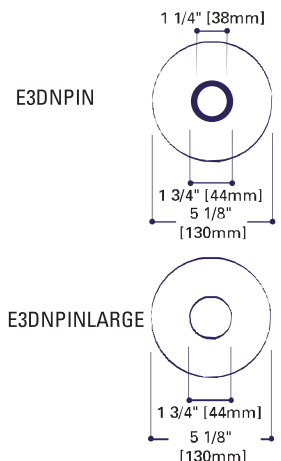

ORDERING INFORMATION

Complete unit consists of a platform, and element

Platform	Optical Element	Flange	Accessories
PN3MR			
PN3MR=3" Airtight Non-IC Low Voltage Housing PN3MR-REMOTE= 3" Airtight Non-IC Low Voltage Housing for Remote Transformer	E3DNPIN = MR16 1-1/4" Downlight Pinhole E3DNPIN-LARGE = MR16 2" Downlight Pinhole	Blank=White with Black Occulus RAW=Natural Die-cast with Black Occulus W = White with white occulus POL = Polished Aluminum with Black Occulus SAL = Satin Aluminum with Black Occulus	MBCLP = 40 Push On T Bar Clips (for 10 Units) PLE3 = Plaster Lip Extension for Max 2" Thick Ceiling FMC3 = Flush Mount Collar LSPD = Spread Lens LLNR = Linear Spread Lens LUV = UV Reduction Lens LLPINK = Light Pink Lens LLSTRAW = Light Straw Lens L27K = 2700K dichroic filter LDAY = Daylight Lens LSPINK = Surprise Pink Lens LPLAV = Pale Lavender Lens LHEX= Hex Cell Louver
		*White Occulus is not available for LARGE pinhole	For additional options please consult factory.

PHOTOMETRICS

PN3MR-E3DNPIN

Test No. H21242
 Lamp: GE Q50MR16C/NSP15
 Lumens: 750
 Cutoff: 50°
 Spacing: 0.2
 Efficiency: 38.7%

Candelas		CD
Vertical Angle		
90		0
85		0
75		0
65		0
55		0
45		0
35		0
25		7
15		42
5		3985
0		5788

Distribution

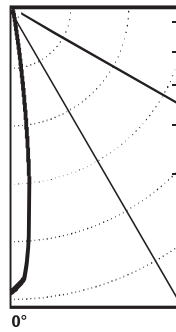

Luminance

Degree	cd/m²
85°	0
75°	0
65°	0
55°	0
45°	0

Cone of Light

Distance to Illuminated Plane	Initial Nadir Footcandles	Beam Diameter
6'	154	1.8
7'	113	2.1
8'	87	2.4
9'	69	2.7
10'	56	3.0
12' 6"	36	3.8
13	33	3.9

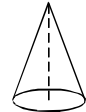

Lamp	Beam	0° Aiming Angle Horizontal Footcandles			
		D	FC	L	W
Q20 MR16/C/VNSP7		6'	87	0.7	0.7
7,400 CBCP		8'	49	0.9	0.9
Lumens: 200		10'	31	1.1	1.1
Spacing: 0.1		12' 6"	20	1.4	1.4
Efficiency: 31.4%	7°	Test # H21233			

Lamp	Beam	0° Aiming Angle Horizontal Footcandles			
		D	FC	L	W
Q45 MR16/IRC/SP8		6'	171	1	1
16,000 CBCP		8'	96	1.4	1.4
Lumens: 1030		10'	62	1.7	1.7
Spacing: 0.2	8°	12' 6"	39	2.2	2.2
Efficiency: 25.0%		Test # H21224			

Lamp	Beam	0° Aiming Angle Horizontal Footcandles			
		D	FC	L	W
Q65 MR16/Q/NSP/B		6'	89	1.4	1.4
14,000 CBCP		8'	50	1.9	1.9
Lumens: 1100		10'	32	2.4	2.4
Spacing: 0.2	10°	12' 6"	20	3	3
Efficiency: 20.1%		Test # H21270			

Lamp	Beam	0° Aiming Angle Horizontal Footcandles			
		D	FC	L	W
Q37 MR16/IR/SP10		6'	151	1.3	1.3
13,100 CBCP		8'	85	1.8	1.8
Lumens: 900		10'	54	2.2	2.2
Spacing: 0.2	10°	12' 6"	35	2.8	2.8
Efficiency: 32.7%		Test # H21258			

Lamp	Beam	0° Aiming Angle Horizontal Footcandles			
		D	FC	L	W
Q50 MR16/C/FL40		6'	38	3.2	2.5
1,700 CBCP		8'	21	4.2	3.4
Lumens: 800		10'	14	5.3	4.2
Spacing: 0.6	40°	12' 6"	9	6.6	5.3
Efficiency: 39.0%		Test # H21206			

Lamp	Beam	0° Aiming Angle Horizontal Footcandles			
		D	FC	L	W
Q65 MR16/Q/FL40		6'	51	2.4	2.4
2,100 CBCP		8'	29	3.2	3.2
Lumens: 1100		10'	18	4	4
Spacing: 0.42	40°	12' 6"	12	5	5
Efficiency: 31.1%		Test # H21262			

Lamp	Beam	0° Aiming Angle Horizontal Footcandles			
		D	FC	L	W
Q42 MR16/C/VNSP9		6'	123	0.8	0.8
12,500 CBCP		8'	69	1	1.6
Lumens: 575		10'	44	1.3	2
Spacing: 0.1	9°	12' 6"	28	1.6	2.5
Efficiency: 21.2%		Test # H21207			

Lamp	Beam	0° Aiming Angle Horizontal Footcandles			
		D	FC	L	W
Q50 MR16/C/NFL25		6'	73	1.8	1.8
3,000 CBCP		8'	41	2.4	2.4
Lumens: 884		10'	26	3	3
Spacing: 0.3	25°	12' 6"	17	3.8	3.8
Efficiency: 39.2%		Test # H21188			

Zonal Lumen Summary

Zone	Lumens	%Lamp	%Luminaire
0-30	290	38.7	99.9
0-40	291	38.7	100.0
0-60	291	38.7	100.0
0-90	291	38.7	100.0
90-180	0	0.0	0.0
0-180	291	38.7	100.0

Coefficient of Utilization

	Ceiling Reflectance											
	80%		70%		50%		30%		0%			
Wall Reflectance	70	50	30	10	50	10	50	10	50	10	0	
Room Cavity Ratio	0	46	46	46	46	45	45	43	43	41	41	39
1	45	45	44	44	44	43	42	42	41	40	39	
2	44	43	43	42	43	41	42	41	41	40	38	
3	44	42	42	41	42	40	41	40	40	39	38	
4	43	42	41	40	41	40	41	39	40	39	38	
5	42	41	40	39	41	39	40	39	40	39	38	
6	42	41	40	39	40	39	40	39	39	38	38	
7	42	40	39	39	40	38	40	38	39	38	38	
8	41	40	39	38	40	38	39	38	39	38	38	
9	41	40	39	38	39	38	39	38	39	38	38	
10	41	39	38	38	39	38	39	38	39	38	37	

Notes and Formulas:

Luminance: To convert cd/m² to footlamberts, multiply by 0.2919

Cone of Light:

- Beam diameter is to 50% of maximum footcandles, rounded to the nearest half-foot.
- Footcandle values are initial. Apply appropriate light loss factors where necessary. See page 64-65 of catalog.

CU Notes/Formulas:

- maintained illuminance = $\frac{\text{lamp lumens} \times \text{CU} \times \text{light loss factors}}{\text{room area}}$
- total number of luminaires = $\frac{\text{total room area} \times \text{maintained illuminance}}{\text{lamp lumens} \times \text{CU} \times \text{light loss factors}}$
- CU data based on 20% effective floor cavity reflectance.

Note: Specifications and Dimensions subject to change without notice.

visit our web site at www.cooperlighting.com

