

DESCRIPTION

Specification grade A lamp fixture for use with narrow joist spacing. Insulation must be kept 3" from fixture sides and top of fixture. The 50° cutoff to lamp and lamp image provides a glare-free,

smooth, medium beam distribution. **Lamp module and optical element can be changed after installation to provide a variety of distributions. e.g. into an Adjustable**

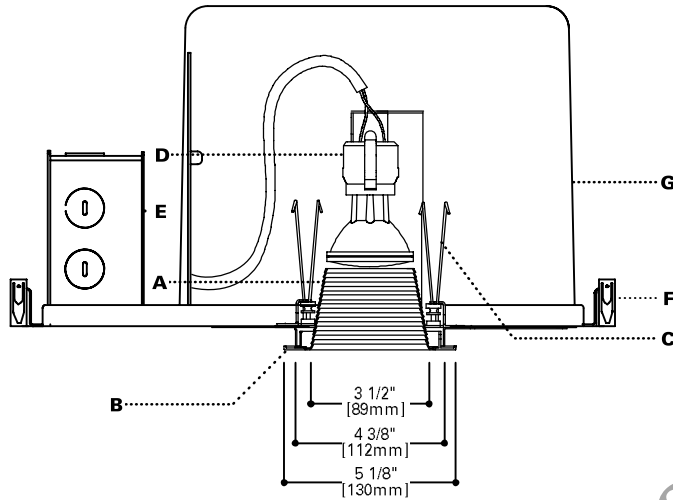

SPECIFICATION FEATURES

A...Baffle

.040 thick aluminum spun sawtooth baffle in black or white powdercoat finish.

B...Flange

Die-cast flange with either matte white or clear coat finish. Die-cast flanges are easily removed for field painting. Elements are keyed for proper insertion.

C...Attachment

Positive torsion springs pull flange tight to ceiling. Mechanical light trap eliminates spill light at edge of flange or baffle.

D...Socket

Nickel plated porcelain socket. Two position socket ensures consistent lamp position.

E...Junction Box

18 cubic inches, listed for 4#12 AWG or 6#14 AWG 90° C additional feed through conductors, has six 1/2 inch pryouts.

F...Bar Hangers

No Flex® bar hangers with positive locking, for use with wood, engineered wood and steel frame joists spaced up to 24" O.C. shipped with platform. For use in T-bar ceilings order accessory MBCLP. Nailless barb and locator lip provide consistent installation height.

G...Frame/Housing

Hot dipped galvanized 20 gauge steel frame with built in 1/2 inch plaster lip. Gunsights allow for consistent alignment. One piece 20 gauge steel housing for seamless construction is painted matte black for a visually dark interior.

Codes

Thermally protected, IP labeled, Unit is airtight and exchanges less than 2.0 CFM with the plenum at a pressure of 75 pascals. Insulation must be kept three inches away from fixture sides and none on top as to entrap heat.

Labels

UL and cUL listed, standard damp label, IBEW union made.

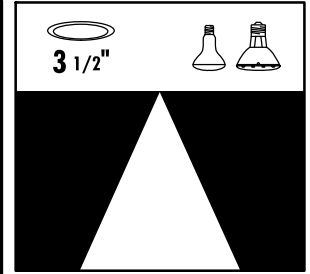

**PN3120
E3P20BB**

- 50W PAR20
- 60W PAR16
- 50W BR19
- 50W R20

**3" DOWNLIGHT
BAFFLE**

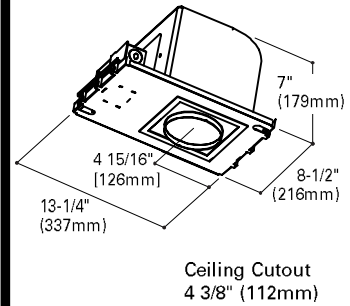

Ceiling Cutout
4 3/8" (112mm)

ORDERING INFORMATION

Complete unit consists of a platform, and element

Platform	Optical Element	Finish	Flange	Accessories
PN3120				
PN3120=3" Airtight Non IC Rated Housing	E3P20= 3" PAR/R Downlight Baffle	BB=Black Baffle WB=White Baffle	Blank=White Die-cast RAW=Natural Die-cast	MBCLP=40 Push On T Bar Clips (for 10 Units) PLE3=Plaster Lip Extension for Max 2" Thick Ceiling FMC3= Flush Mount Collar

PHOTOMETRICS

PN3120-E3P20BB

Test No. H21057
 Lamp: 50PAR20NFL
 Lumens: 560
 Cutoff: 50°
 Spacing: 0.5
 Efficiency: 62.0%
 Unit LPW: 6.94

Candelas	
Vertical Angle	CD
90	0
85	0
75	0
65	0
55	1
45	1
35	8
25	148
15	595
5	1261
0	1312

Distribution

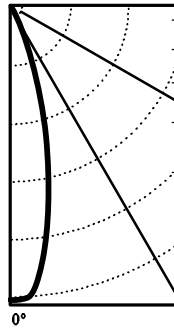

Luminance

Degree	cd/m ²
85°	0
75°	0
65°	0
55°	281
45°	228

Cone of Light

Distance to Illuminated Plane	Initial Nadir Footcandles	Beam Diameter
4'6"	65	2'0"
5'6"	43	2'6"
6'6"	31	3'0"
8'0"	20	4'0"
10'0"	13	5'0"
12'0"	9	6'0"

Zonal Lumen Summary

Zone	Lumens	%Lamp	%Luminaire
0-30	339	60.5	97.7
0-40	345	61.7	99.5
0-60	347	62.0	100.0
0-90	347	62.0	100.0
90-180	0	0.0	0.0
0-180	347	62.0	100.0

Coefficient of Utilization

Ceiling Reflectance	80%		70%		50%		30%		0%	
	70	50	30	10	50	10	50	10	50	10
Room Cavity Ratio	70	50	30	10	50	10	50	10	50	10
0	74	74	74	74	72	72	69	69	66	66
1	72	71	70	69	69	68	67	66	65	64
2	70	68	66	65	67	64	65	63	63	62
3	68	66	64	63	65	62	64	61	62	60
4	67	64	62	61	64	60	62	60	61	59
5	65	62	60	59	62	59	61	58	60	58
6	64	61	59	58	61	57	60	57	59	57
7	63	60	58	56	59	56	59	56	58	55
8	61	58	56	55	58	55	57	55	57	54
9	60	57	55	54	57	54	56	53	56	53
10	59	56	54	53	56	53	55	52	55	52

PN3120-E3P20WB

Test No. H21062
 Lamp: 50PAR20NFL
 Lumens: 560
 Cutoff: 50°
 Spacing: 0.5
 Efficiency: 66.0%
 Unit LPW: 7.39

Candelas	
Vertical Angle	CD
90	0
85	1
75	2
65	4
55	7
45	7
35	14
25	153
15	578
5	1258
0	1373

Distribution

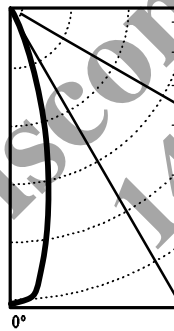

Luminance

Degree	cd/m ²
85°	1848
75°	1244
65°	1524
55°	1965
45°	1594

Cone of Light

Distance to Illuminated Plane	Initial Nadir Footcandles	Beam Diameter
4'6"	68	2'0"
5'6"	45	2'6"
6'6"	32	3'0"
8'0"	21	3'6"
10'0"	14	4'6"
12'0"	10	5'5"

Zonal Lumen Summary

Zone	Lumens	%Lamp	%Luminaire
0-30	341	60.9	92.2
0-40	351	62.7	94.9
0-60	362	64.7	97.9
0-90	370	66.0	100.0
90-180	0	0.0	0.0
0-180	370	66.0	100.0

Coefficient of Utilization

Ceiling Reflectance	80%		70%		50%		30%		0%	
	70	50	30	10	50	10	50	10	50	10
Room Cavity Ratio	70	50	30	10	50	10	50	10	50	10
0	79	79	79	79	77	77	73	73	70	70
1	76	75	73	72	73	71	71	69	68	67
2	74	72	70	68	70	67	68	66	67	64
3	72	69	67	65	68	65	67	64	65	61
4	70	67	64	63	66	62	65	62	64	59
5	68	65	62	60	64	60	63	60	62	58
6	67	63	61	59	63	59	62	58	61	57
7	65	61	59	57	61	57	60	57	59	55
8	64	60	57	56	59	55	59	55	58	54
9	62	58	56	54	58	54	57	54	56	53
10	61	57	55	53	57	53	56	53	56	52

Notes and Formulas:

Luminance: To convert cd/m² to footlamberts, multiply by 0.2919

Cone of Light:

- Beam diameter is to 50% of maximum footcandles, rounded to the nearest half-foot.
- Footcandle values are initial. Apply appropriate light loss factors where necessary. See page 64-65 of catalog.

CU Notes/Formulas:

- $\text{maintained illuminance} = \frac{\text{lamp lumens} \times \text{CU} \times \text{light loss factors}}{\text{room area}}$
- $\text{total number of luminaires} = \frac{\text{total room area} \times \text{maintained illuminance}}{\text{lamp lumens} \times \text{CU} \times \text{light loss factors}}$
- CU data based on 20% effective floor cavity reflectance.

Note: Specifications and Dimensions subject to change without notice.

Visit our web site at www.cooperlighting.com

