

Index Series

Individual Luminaires: 2', 4', 6' 8' and 12'

**WARNING:** Before starting any work ensure that all sources of power are turned off. All work must meet local/national electrical codes and be performed by a certified electrician.

1. Removing Fixture Channel from Packaging

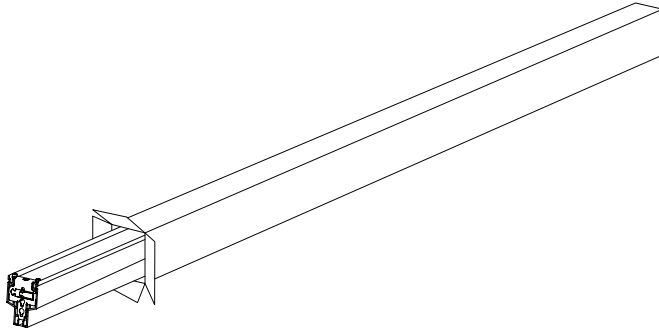

- A. Linear boxes contain fixture channel. Larger, rectangular boxes contain optical panels. Begin installation with fixture channel.
- B. Using CLEAN work gloves, carefully fixture channel from packaging.
- C. Leave optical panels in box until installation is complete.

**NOTE: AVOID CONTACT WITH LENSES**

2. Removing Top Cover

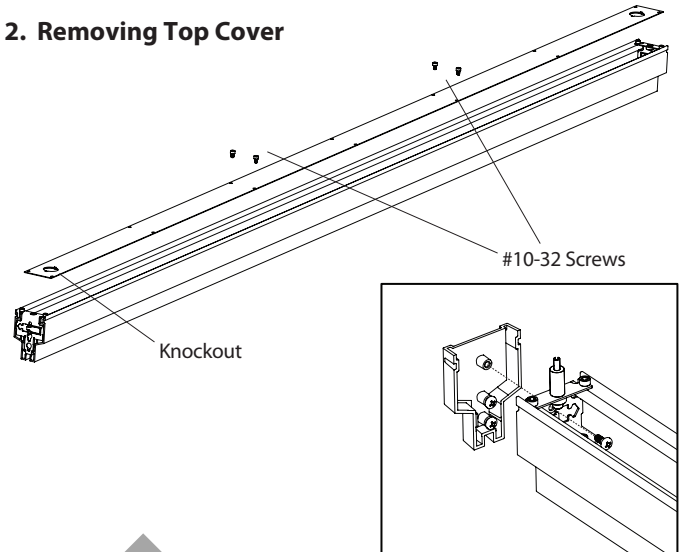

- A. Remove #10-32 screws from top cover to access wiring.
- B. Remove knockout closest to power feed.
- C. Using keyhole slots on fixture ends, press and shift endcap onto channel end. Secure endcap using provided #10-32 screw. Repeat on opposite end.

3. Wiring and Hanging Fixture Channel



- A. Install cable grippers on each end of fixture channel.
- B. Using provided SJ cable, make appropriate wire connections and feed through top cover. Secure with provided strain relief. Secure top cover with screws.
- C. Insert aircraft cable into gripper ends and secure fixture to ceiling structure using additional mounting instructions for particular ceiling type.

Not all options available. Please consult your Cooper Lighting Solutions Representative for availability. Specifications and Dimensions subject to change without notice.

Index Series

Individual Luminaires: 2', 4', 6' 8' and 12'

**WARNING:** Before starting any work ensure that all sources of power are turned off. All work must meet local/national electrical codes and be performed by a certified electrician.

4. Removing Optical Panels from Packaging

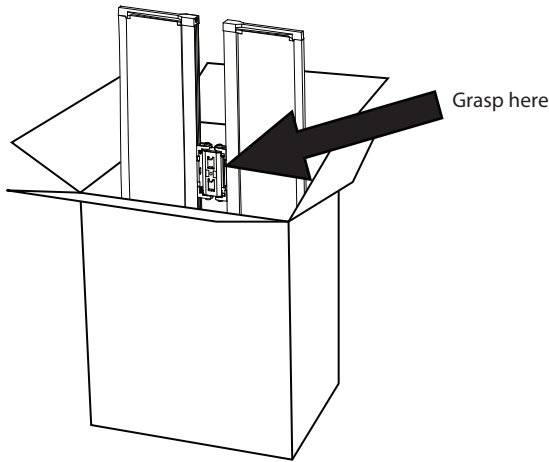

A. Once fixture channel is installed, using CLEAN work gloves, carefully remove fixture channel from packaging.

B. Leave plastic wrap on panels until installation is complete

**NOTE: AVOID CONTACT WITH LENSES**

5. Prepare Panel for Installation

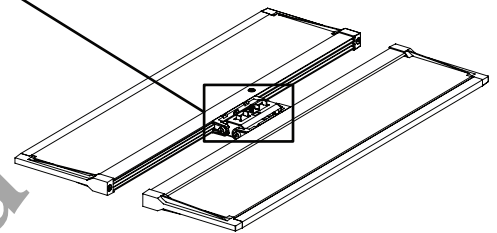
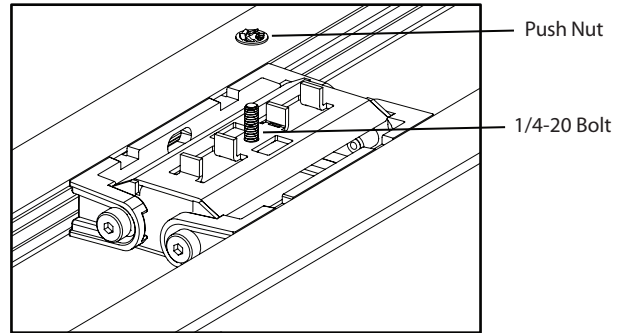

A. Remove wiring cover

B. Insert 1/4-20 bolt into panel yoke and secure with push nut.

6. Installing Panels onto Fixture Channel

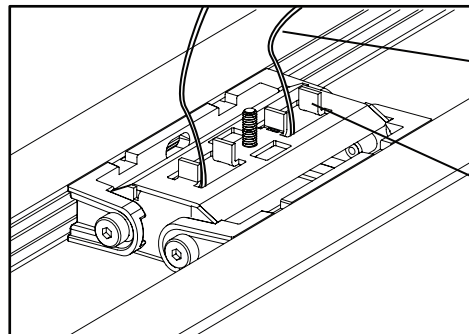
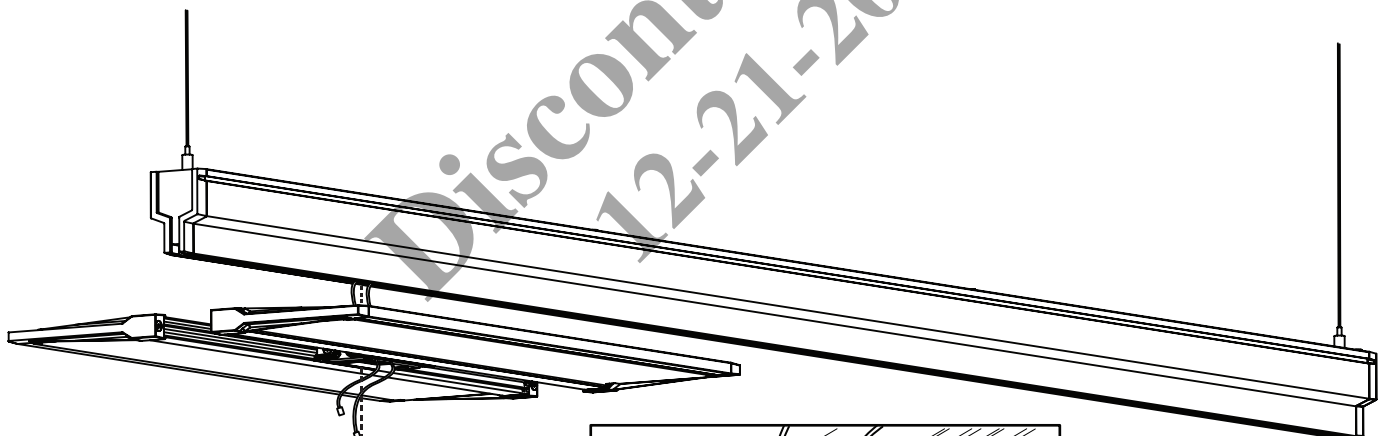

A. Run quick disconnects from fixture channel through top holes on panel yoke. Secure panel yoke with 1/4-20 bolt to fixture channel. Ensure tabs seat within fixture channel.

B. Match and connect wiring terminals and push into panel yoke. Secure cover plate. Repeat for additional panels.

Not all options available. Please consult your Cooper Lighting Solutions Representative for availability. Specifications and Dimensions subject to change without notice.