

Project		Catalog #		Type	
Prepared by		Notes		Date	



# Greengate

## ONW-D-NeoSwitch

Dual Tech/Dual Relay Wall Switch Sensor  
(Neutral Required)

### Typical Applications

Office • Small Conference Rooms • Lunch/Break Rooms • Classrooms • Restrooms (1-2 Stalls) • Lounges • Waiting Rooms • Closets • Storage Areas

### Interactive Menu

- Order Information page 2
- Additional Resources page 2
- Wiring Diagrams page 3
- Connected Systems page 4
- Product Warranty

### Product Certification



### Product Features



### Top Product Features

- Air-gap switch ensures no leakage current to load
- Selectable built-in light level sensor
- NEMA WD7 Guide robotic method utilized to verify coverage patterns
- Additional pushbutton with light/fan graphic included
- LED Rated

### Dimensional and Mounting Details

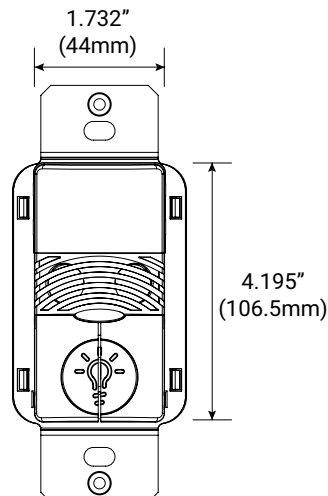

### Scale or Mounting Height

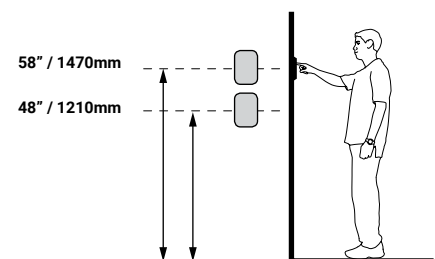

[additional product diagrams](#)

## Order Information

SAMPLE ORDER NUMBER: **ONW-D-1001-DMV-N-W**

One single gang wallplate included

### Catalog Number

Catalog Number	Ratings	Coverage	Voltage	Color
<b>ONW-D-1001-DMV-N-*</b> (*-W, V, LA, G, B, R)	Incandescent: 0-800W @ 120V Fluorescent: 0-1200W @ 120V Fluorescent: 0-2700W @ 277V Max Load/Relay	180°; 1000 sq. ft.	120/277 VAC, 50/60 Hz	W=White, V=Ivory, LV=Light Almond, G=Gray, B=Black, R=Red
				<b>Notes</b> Not all colors are available in stock and some color options may have extended lead times.

## Product Specifications

### Technology

- Passive Infrared (PIR) and Ultrasonic (US) technology

### Mechanical

**Mounting Plate/Strap Dimensions:** 4.195" H x 1.732" W (106.55mm x 44mm)

**Product Housing Dimensions:** 2.618" H x 1.752" W x 1.9" D (66.5mm x 44.5mm x 48.26mm)

### Environment:

- Operating temperature:** 32°F to 104°F (0°C to 40°C)
- Relative humidity operating:** 20% to 90% non-condensing
- For indoor use only

**Housing:** Durable, injection molded housing. ABS resin complies with UL 94V-0

**Mounting:** Fits in a standard 3.5" deep back box Can be mounted in multiple gang back box Refer to NEC box calculation for properly sized mounting box

### Electrical

#### Electrical ratings (per relay):

- 120 VAC
  - Incandescent / Tungsten max load: 6.7 amps, 800W, 50/60 Hz
  - Fluorescent / Ballast max load: 10 amps, 1200W, 50/60 Hz
  - Electronic Ballast (LED): 3A
  - Motor Load: 1/4 HP @ 125 VAC
- 277VAC
  - Fluorescent / Ballast max load: 9.8 amps, 2700W, 50/60 Hz
  - Electronic Ballast (LED): 3A

#### Ballast compatibility:

- LED loads
- Magnetic and Electronic ballasts

## Overview

The Dual Technology Dual Relay Occupancy Sensing Wall Switch is a motion sensing lighting control and conventional wall switch all-in-one that is used for energy savings and convenience. The unit contains two relays that allow the control of two separate loads. It does not require a neutral wire for installation making it ideal for retrofit applications.

The ONW-D-1001-DMV combines Ultrasonic (US) and Passive Infrared (PIR) sensor technologies to monitor a room for occupancy to deliver maximum energy savings and ensure the greatest sensitivity and coverage for tough applications without the threat of false triggers. PIR is used to turn the lights ON and then either or both technologies are used to keep the lights ON. In Automatic On Mode, the lights turn ON when a person enters the room. In Manual On Mode, the lights are turned ON by pressing the universally recognized light icon pushbutton. Each relay can be set independently to Automatic or Manual On Mode. The sensor includes self-adaptive technology that continuously self-adjust sensitivity and time delay in real-time, maximizing the potential energy savings that are available in the particular application.

### Hardware Specifications

#### LED Indicators:

- Red LED = PIR detection
- Green LED = Ultrasonic detection; Green LED acts as EcoMeter or nightlight locator

### Controls and Performance

#### Time delays:

- Self adjusting 15 seconds/test (10 min. Auto)
- Selectable 5, 15, 30 minutes

#### Coverage:

- Major motion: 36' x 30'
- Minor motion: 20' x 16'

#### Light sensing level:

- 0 to 200 foot candles

### Standards/Ratings

- cULus Listed - Energy Management Equipment (UL916)
- FCC Compliant
- RoHS Compliant

### Warranty

Five year warranty standard

## Wiring Diagrams

120/277 VAC dual level single circuit wiring diagram

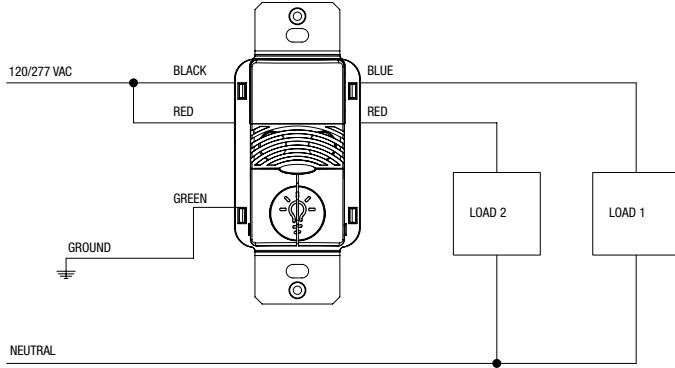

120/277 VAC dual level dual circuit wiring diagram

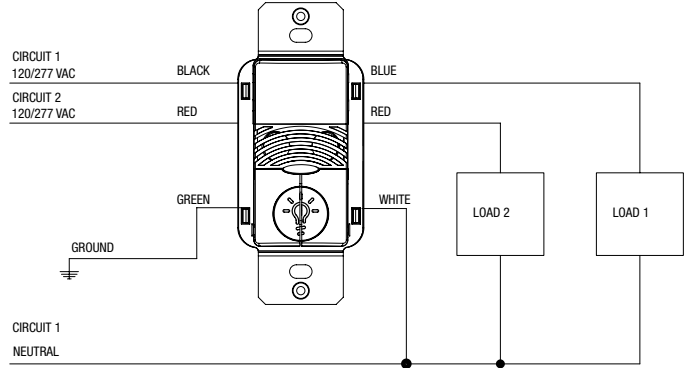

Three-way wiring diagram: Lights will turn OFF automatically when sensor that detected motion last, times out.

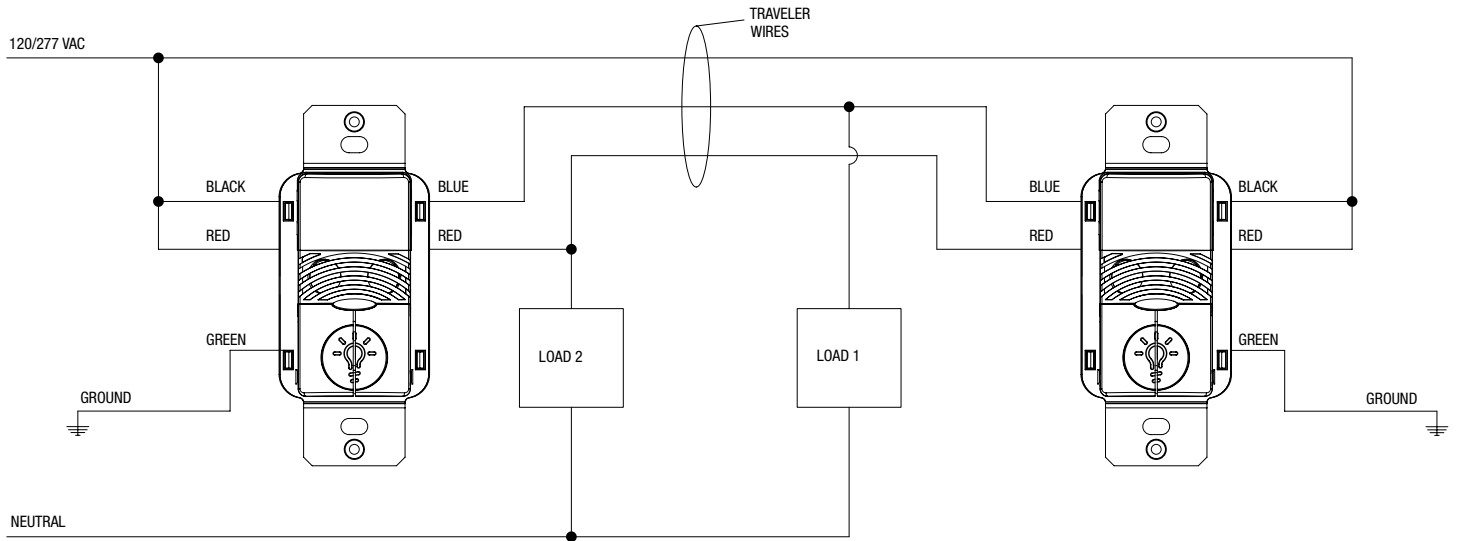

## Controls

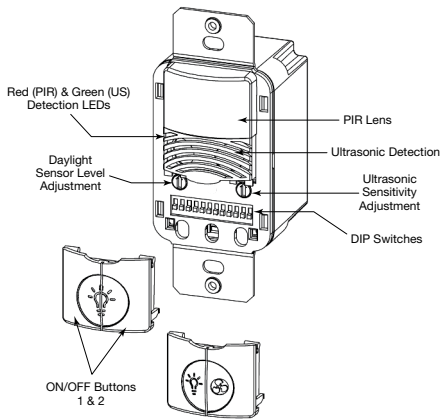

DIP Switch Legend

DIP Switch	Time Delay		Activation		PIR Sensitivity	Walk-Through Mode	EcoMeter	Override	Bathroom	Relay Swap	Daylighting	
	1	2	Relay 3	Relay 4							Relay 1	Relay 2
Auto*	▼	▼	Auto	Auto	Full	Disable	Enable	Disable	Disable	Normal	Disable	Disable
5 Minutes	▼	▲	Manual	Manual	50%	Enable	Disable	Enable	Enable	Swap	Enable	Enable
15 Minutes	▲	▲										
30 Minutes	▲	▲										
*Self-Adjusts to 10 min. user mode												

Default =

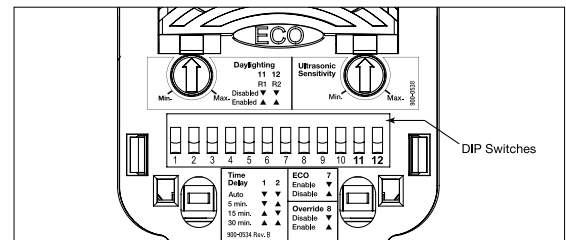

## Field of View

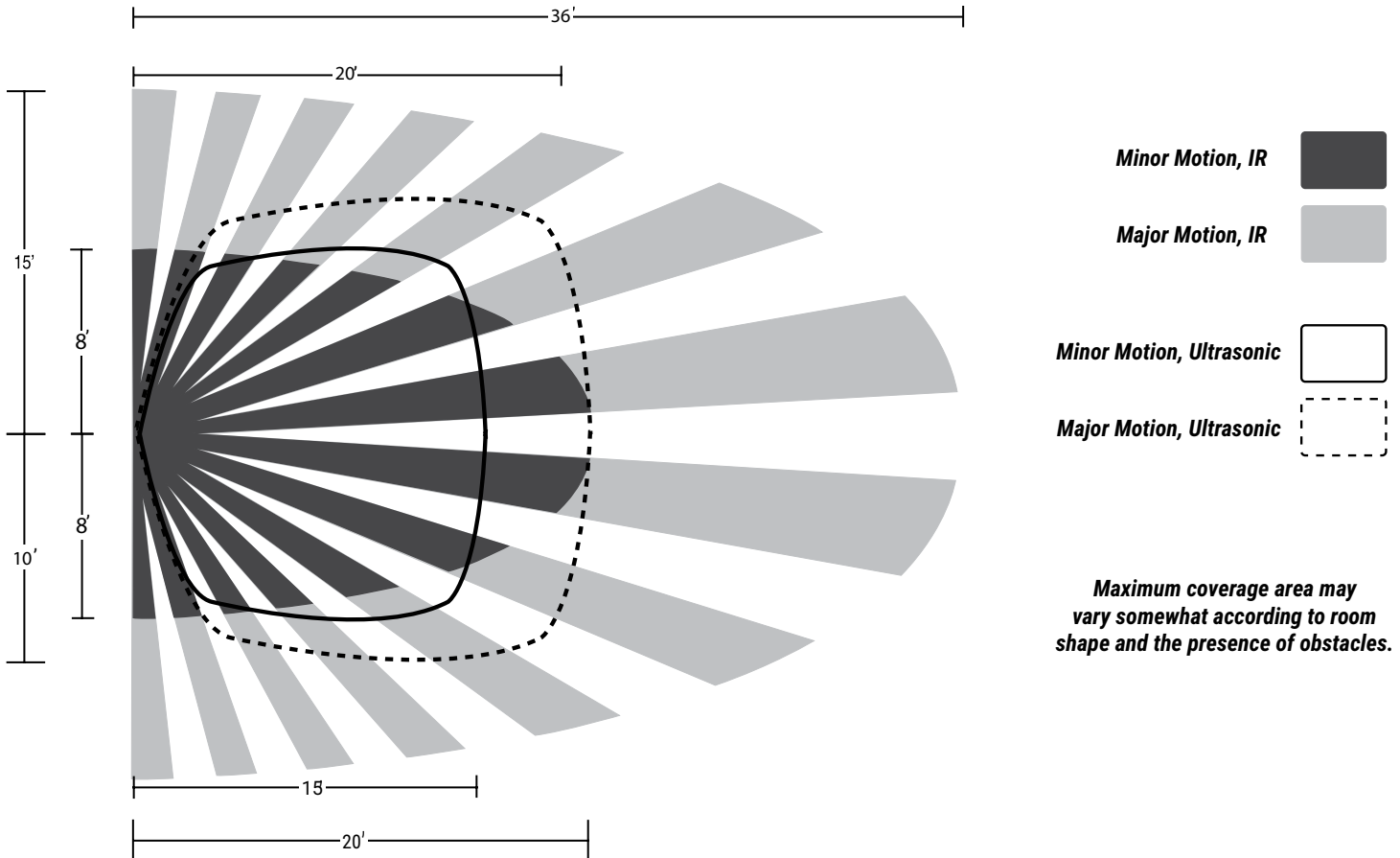

 **Control Systems**  
• Greengate