

**DESCRIPTION**

MWS-5LT, Modular Wiring Systems with DALI Control, provides low cost installation of both power for lighting and Class 1 control wiring for use with Fifth Light DALI systems. Using modular components that plug together, MWS-5LT can be installed in a fraction of the time of hardwiring both lighting and control. Plus, MWS-5LT offers the advantage of relocating fixtures and DALI control devices for future renovations.

The MWS T Cable with DALI Control (TC-5LT) feeds power and control wiring to wall or ceiling fixtures while feeding downstream to another fixture. Compatible MWS Extender Cables (EC) are used connect either end of the TC-5LT. See the Extender Cable specification sheet for compatible models.

MWS Extender Cables feed power to each T Cable.

**DESIGN FEATURES**

- UL Listed under Standard 183 for make or break under load.
- Meets requirements of Article 604 of the National Electrical Code.
- MWS components assembled with 12 AWG conductors rated at 20 amperes with full size ground wire.
- Copper conductors are THHN insulated wire rated 90°C.
- Galvanized steel exterior with integral keying for voltage and amperage.
- Valox 365 constructed contact housings are approved for environmental air plenums.
- Allows downstream feeding of circuits to another electrical component or fixture.
- Cable end supplied with 1/2" connector with locknut and 6" pre-stripped leads.

<b>Catalog #</b>		<b>Type</b>
<b>Project</b>		
<b>Comments</b>		<b>Date</b>
<b>Prepared by</b>		



**TC-5LT**

**T CABLE**  
Modular Wiring System



**DIMENSIONAL DATA**

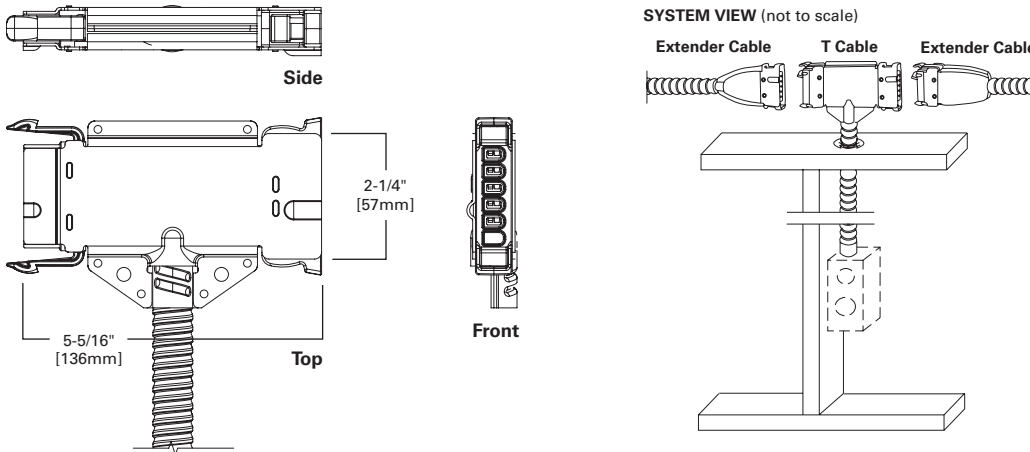

**ORDERING INFORMATION**

SAMPLE NUMBER: 27TC12/4G095LT

	<b>TC</b>			
<b>Voltage</b> 12=120V 27=277V	<b>Component</b> TC=T Cable	<b>Conductors and Size</b> 12/4G=#12, 4 Conductors Plus Ground	<b>Cable Length (Feet)</b> 01=1' 09=9' 15=15'	<b>Options</b> 5LT

Specifications & dimensions subject to change without notice. Consult your Cooper Lighting Solutions Representative for availability and ordering information.

**SHIPPING DATA**

Cable Length	Unit Wt.	Standard Qty./Carton
1'	1.0 lbs.	12
9'	3.5 lbs.	8
15'	5.0 lbs.	6

**MWS AUTOCAD DRAFTING**

MWS offers AutoCAD drafting to layout MWS, providing the contractor with additional benefits. MWS design layout time is reduced. Bills of material are computer-generated guaranteeing accuracy. MWS drawing symbols and details standardized. Layouts are available on CD or e-mail. To utilize this service and for additional information, contact the MWS Sales Department (888) 487-4887.

All electrical boxes, conduit, connections and switches by others.

Install dust covers on unused open ends.

Scale is exaggerated on fixtures and MWS system applications.