

Project		Catalog #		Type	
Prepared by		Notes		Date	

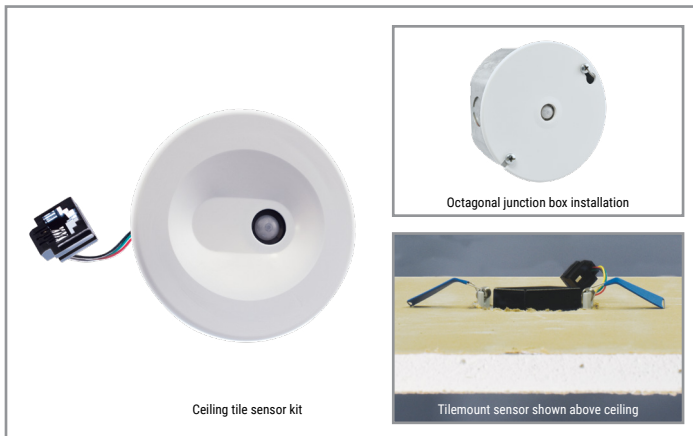

WaveLinX

PRO Tilemount Sensor Kit without control module (WTE)

Provides motion sensing, daylight dimming and additional RTLS sensing capabilities outside of fixture integrated components

Typical Applications

Office • Education • Healthcare • Hospitality • Retail
Industrial • Manufacturing

Interactive Menu

- Order Information page 2
- Additional Resources page 3
- Wiring Diagrams page 4
- Connected Systems page 7
- Product Warranty



- Meets latest ASHRAE Standard 90.1 requirements
- Meets latest IECC requirements
- Meets latest CEC Title 24 requirements

Product Features



Compatibility



Overview

The WaveLinX PRO Tilemount Sensor Kit is an integral part of the WaveLinX connected lighting system and offers 120-277VAC 3 amp zero crossing relay control and continuous 0-10V dimming control of LED and non-LED loads. The intended use of the Tilemount Sensor Kit is to provide daylight dimming and control for connected downlight luminaires or other luminaires that do not support the WaveLinX PRO integrated sensor.

The Tilemount Sensor Kit is powered by the 120-277VAC circuit it is controlling and allows simple electrical junction box mounting via 1/2" knock out or direct connection to the junction box attached to connected luminaire. The WaveLinX PRO Tilemount Sensor Kit operates on a wireless mesh network based on IEEE 802.15.4 standards and is controlled by the WaveLinX Area Controller.

Product Features & Benefits

- External plenum rated power source for multiple sensor connectivity (up to 16 sensors)
- Multiple pre-terminated plenum rated cable options available
- Mounting heights of 8 to 15ft (2.4 to 4.5m)
- Provides passive infrared (PIR) motion coverage up to 500 sq-ft (46m²)
- Sensor installs into 1/2 - 3/4" (12 - 19mm) ceilings or octagonal junction boxes
- Hardware capable of Real Time Location Services (RTLS) - WaveLinX CORE Locate license required

Order Information

The WaveLinx PRO Tilemount Sensor kit and Power Supply are accessories to the WaveLinx connected lighting system and requires a WaveLinx Area Controller (WAC) for full functionality.

The wireless tilemount sensor kit is used to provide occupancy sensing in spaces and can be mapped to other sensors in an area for maximum coverage and control.

The wireless tilemount sensor kit is typically used to provide additional Real Time Location (RTLS) sensing points in a space (WaveLinx CORE Locate license required) in addition to PIR motion sensing.

Catalog Number	Catalog Number	Catalog Number

Catalog Number	Description
WTE	Wavelinx PRO Tilemount Sensor Kit without Control Module
WLX-PS-SENSOR	Wavelinx PRO Tilemount Sensor Power Supply
WLX-CABLE-054	Wavelinx PRO Sensor Cable 54in
WLX-CABLE-084	Wavelinx PRO Sensor Cable 84in
WLX-CABLE-180	Wavelinx PRO Sensor Cable 180in
WLX-CABLE-360	Wavelinx PRO Sensor Cable 360in
WLX-CABLE-SPL	Wavelinx PRO Sensor Cable Splitter
WLX-CABLE-CPL	Wavelinx PRO Sensor Cable Coupler

Required Accessories

All WaveLinx connected lighting system accessories require at least one WaveLinx Area Controller (WAC) for communications. Ensure the bill of material includes one of the following components.

Catalog Number

Catalog Number	Description
WAC2-POE	WaveLinx Area Controller G2, PoE powered
WAC2-120	WaveLinx Area Controller G2 with 120VAC to PoE Injector

Optional Accessories

For connection to 120VAC outlets.

Catalog Number

Catalog Number	Description
WPOE2-120	120VAC to PoE Injector

Product Specifications

Key Features

Kit Contents:

- Sensor
- 54" Plenum rated cable
- Tile and 4" octagon mounting trim
- Easily enable 0-10V luminaires to be controlled by WaveLinx
- Provides closed loop daylighting control of non-integrated luminaires
- Control module mounting to junction box or luminaire driver compartment
- Sensor installs into 1/2 - 3/4" (12 - 19mm) ceilings or octagonal junction boxes
- Ceiling white trims that can be painted for custom appearance
- Mounting heights of 8 to 15ft (2.4 to 4.5m)
- Provides passive infrared (PIR) motion coverage up to 500 sq-ft (46m²)
- Hardware capable of Real Time Location Services (RTLS)
CORE Locate license required
- Energy calculations available through WaveLinx CORE

Mechanical

Tilemount Sensor Size: 2.8" x 2.8" x 1.2" (70mm x 70mm x 31mm)

J-Box Sensor Size: 4.1" x 4.1" x 1.0" (105mm x 105mm x 24mm)

Environment:

- **Operating temperature:** -4°F to 131°F (-20°C to 55°C)
- **Storage temperature:** -40°F to 158°F (-40°C to 70°C)
- **Relative humidity operating:** 5% to 95% non-condensing
- For indoor use only

Mounting Height: 8-15ft (2.4 to 4.5m)

Ceiling hole diameter: 2.9" (73mm)

Ceiling thickness: 0.5 to 0.75" (12 - 19mm) drop ceiling thickness

Color: Matte white (field paintable trim)

Housing: UV stabilized plastic

Electrical

- 120/277VAC incoming and switched power
- 10mA 0-10V sink (refer to driver specifications to calculate quantity supported)
- 3A LED loads

Software Specifications

- Any number of sensors can be mapped to any number of zones
- Remote configuration of occupancy sensing and closed loop daylighting

Wireless Specifications

Radio: 2.4GHz

Standard: IEEE 802.15.4

Transmitter Power: + 7dBm

Range: 75ft (25m) LOS

of Walls: 2 interior walls standard construction

Standards/Ratings*

- cULus Listed
- Meets latest ASHRAE Standard 90.1 requirements
- Meets latest IECC requirements
- Meets latest CEC Title 24 requirements

Environmental Regulations:

- RoHS Directive 2011/65/EU

Warranty

- Five year warranty standard



Download the WaveLinx Mobile App from either the Google Play or Apple Store®

Dimensional Details

Sensor for Tilemount installation

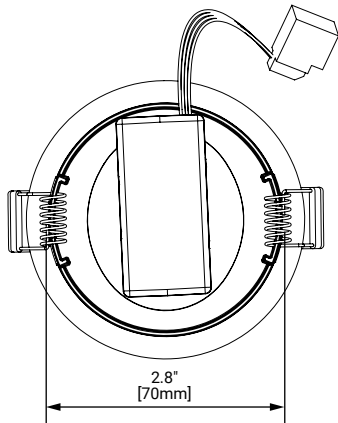

Sensor for J-Box installation

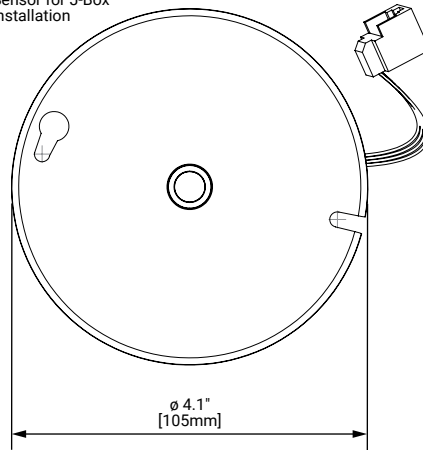

Mounting Height

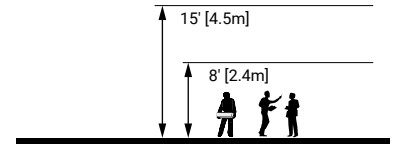

Wiring Diagrams

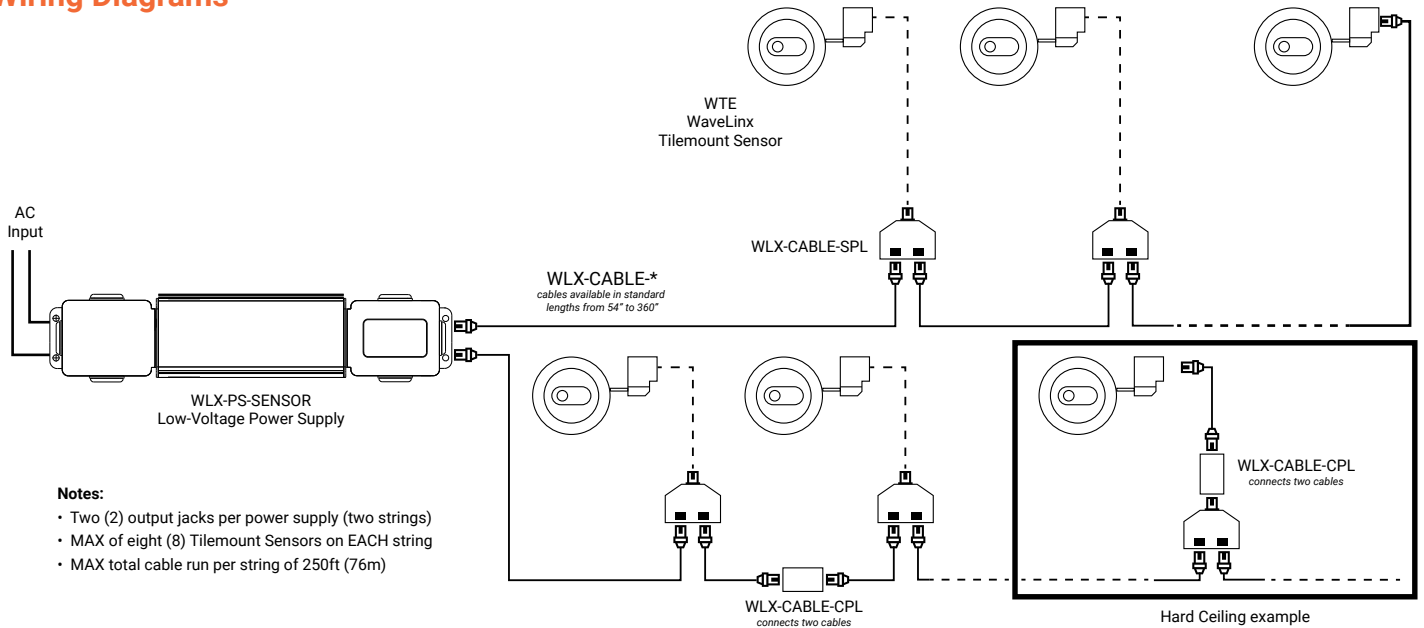

Tilemount Installation

Step 1:
Cut 2-7/8" (73mm) to 3" (76mm) diameter hole in ceiling tile.

Step 2:
Connect plenum cable connectors.

Step 3:
Snap sensor body into ceiling trim.

Step 4:
Squeeze trim springs and insert through hole.

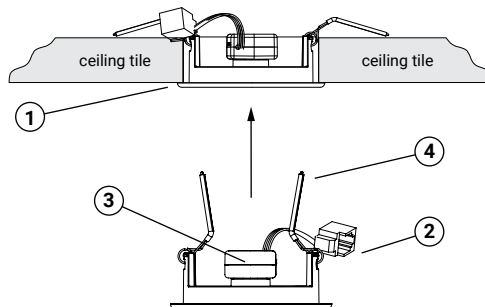

J-Box Installation

- Step 1:**
Snap sensor body into cover plate.
- Step 2:**
Pull plenum sensor cable through junction box knockout.
- Step 3:**
Connect plenum cable connectors.
- Step 4:**
Secure sensor kit to junction box.

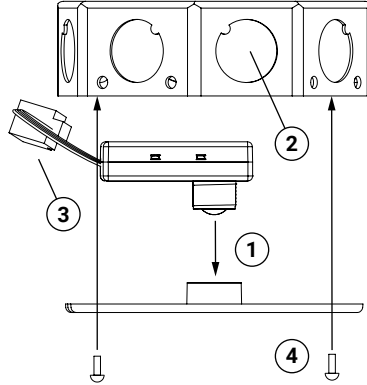

Additional Dimensional Details - Tilemount Sensor

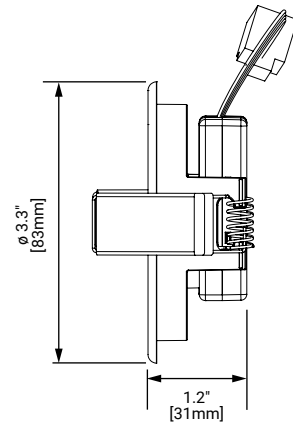
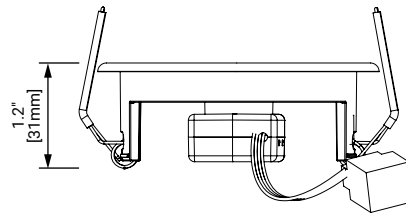
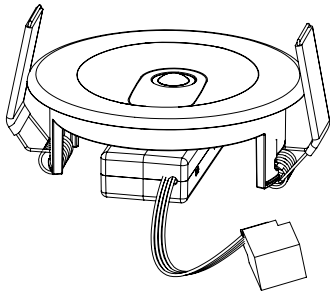

Additional Dimensional Details - J-Box Sensor

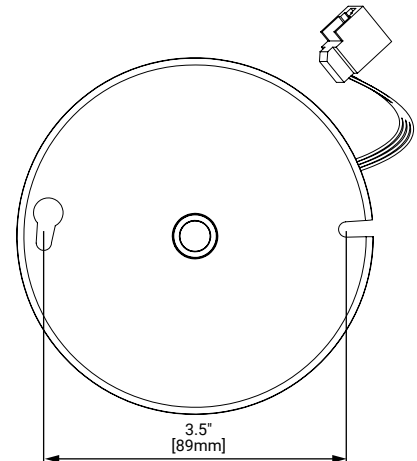
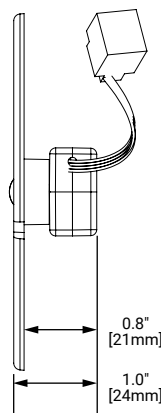
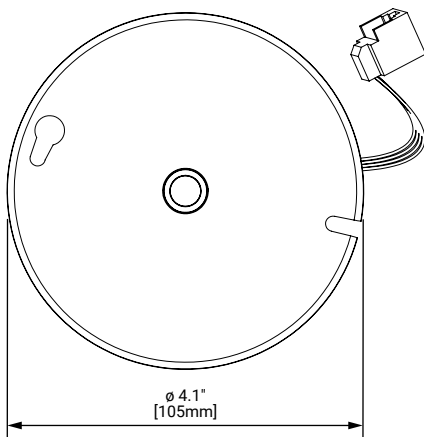

Field of View

TOP VIEW:

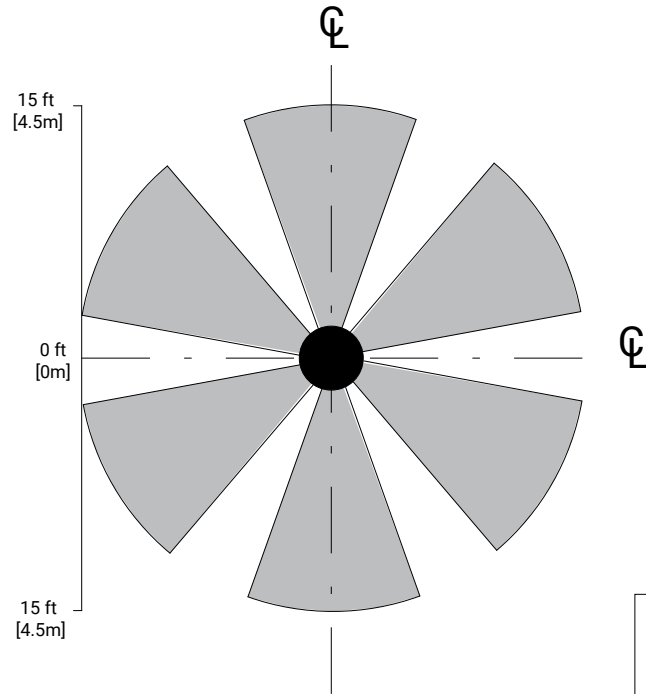

Notes: (1) The coverage pattern shown above depicts the area below the luminaire where the integrated sensor system can detect occupancy. (2) Spacing between fixtures should not exceed the coverage pattern of the sensor. (3) Mounting height should not exceed coverage shown. (4) Exceeding these spacing/height guidelines will result in reduced integrated sensor performance.

SIDE VIEW:

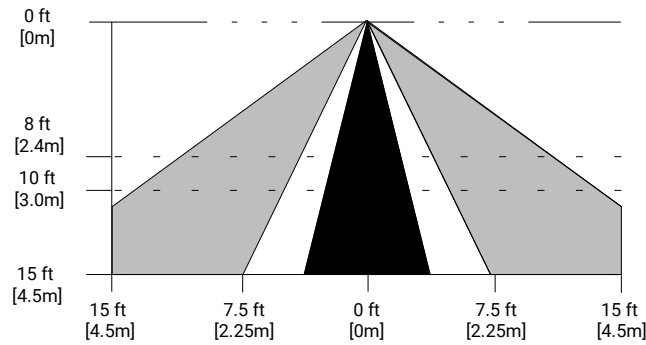

Recommended Mounting Height 8 to 15 ft [2.4 to 4.5m].

Note - coverage pattern not to scale

System Diagram:

This diagram shows the main components of the WaveLinx connected lighting system with WaveLinx DALI, CAT and PRO devices. The PRO devices communicate using wireless mesh technology based on the IEEE 802.15.4 standard. A PoE LAN connection for each WaveLinx Area Controller (WAC) is required for power and data access to the building lighting network. The CAT devices communicate over the category 5 based communication bus and control the light fixtures using a relay (on/off) and 0-10V output (dim/raise). WaveLinx DALI devices communicate via a DALI bus (2 wires), which connects various components including DALI fixtures, a DALI DAC (DALI to 0-10V converter), DALI field relays, DALI wallstations, and DALI occupancy sensors. WaveLinx Area Controllers (WAC) communicate with WaveLinx CORE Apps over the Ethernet network.

[View WaveLinx Network and IT Guidance Technical Guide](#)

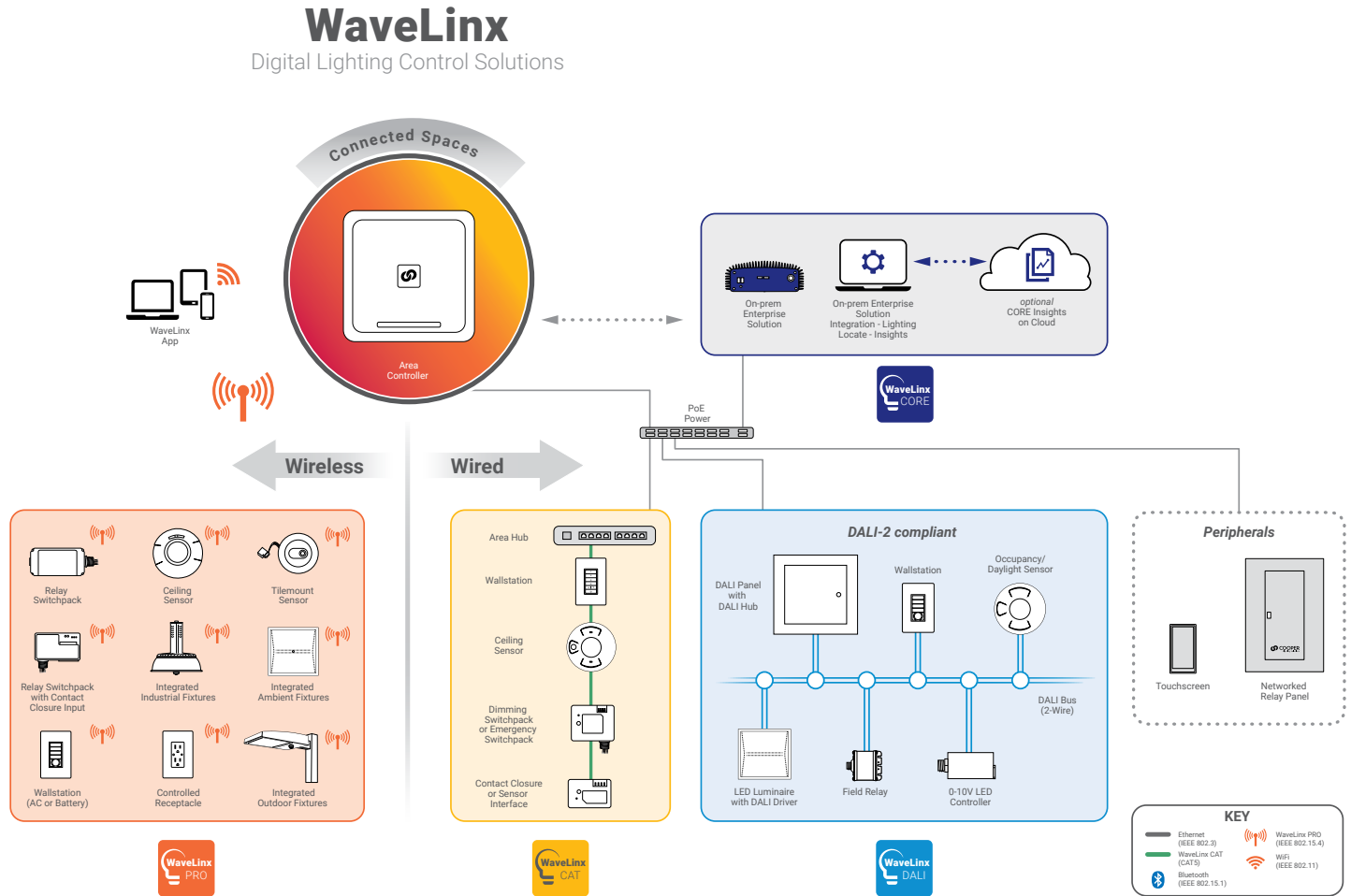

Control Systems
• WaveLinx