

Project		Catalog #		Type	
Prepared by		Notes		Date	

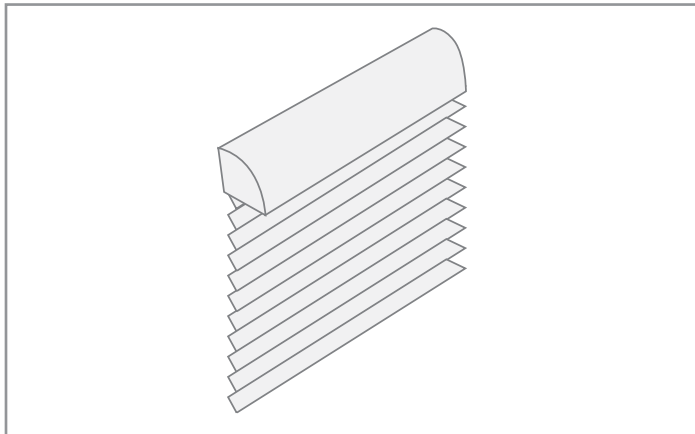

Fifth Light Shade Interface

Leverage Fifth Light's DALI Wallstations and Low Voltage Wallstations to control 3rd party blind and shades

Typical Applications

Office • Education • Healthcare • Hospitality • Retail

Interactive Menu

- Order Information page 2
- Additional Resources page 2
- Product Warranty

Product Features



Top Product Features

- The Shade Interface allows users to integrate the Fifth Light system with leading shade control systems providers, i.e. MechoSystems, and Somfy®
Note: For other shade manufacturers, the integration is done via digital output cards
- It allows users to send comprehensive commands (up, down, go to scene, position and stop) to the shade controllers from a DALI Wallstation or a Low Voltage Wallstation
- Support shades manufacturers native protocol - send up, down, go to scene, stop, position commands to Somfy, MechoSystems shades controller using shade manufacturers native protocol

Order Information

A Shade Interface software license is required when integrating the Fifth Light system with MechoSystems and Somfy shade controllers. The Shade Interface software license is not required when integrating with a shade controller using DALI Field Relays, digital output and relay output devices.

Catalog Number

Catalog Number	Description	Communication Bus	Integration
FLT-SHADE	Enabling the shade integration on the Lighting Management Server	MechoNET RS-232 Protocol and Somfy RS-485 Protocol	DALI and shade control
Notes FLT-SHADE does not include the services required to integrate the lighting control system with the shades control system.			

Additional Accessories

Additional components may be required for integration from shade manufacturer. Consult shade manufacturer for more information.

Product Specifications

Key Features

- The Shade Interface allows facility managers to define the manner in which lights and shades work together. By doing so, both systems automatically work in concert with one another in order to maximize energy savings and increase user comfort.
- Users can override the position of the shades and the level of the electric lights using a single device in order to achieve desired lighting condition. Fifth Light's DALI Wallstations and Low Voltage Wallstations can be used to control both the shading and lighting in an integrated and seamless manner.
- The integration is accomplished from within the Lighting Control Panel (LCP).

Software Specifications

System Requirements:

- Lighting Control Panel (LCP)

Communication Protocols:

- MechoNet RS-232 Protocol (MechoSystems)
Note: Via ethernet to RS-232 serial adaptor
- Somfy RS-485 Protocol (Somfy)
Note: Via ethernet to RS-485 serial adaptor

Control Specifications

Support Shade Controllers:

- MechoSystems IQ/MLC2
- Somfy ILT 50 motors

Warranty

Consult website for warranty information

Supported Commands

Manufacturer	Communication Protocol	Command					
		Up	Down	Stop	Go To Scene	Position	Tilt
Somfy	Ethernet to Serial	✓	✓	✓	X	✓	X
MechoSystems	Ethernet to Serial	✓	✓	✓	✓	X	X

System Architecture

This diagram illustrates the main components of the Fifth Light system. The DALI wallstations, DALI multi-sensors, DALI field relay, DALI dimming module, DALI DAC and DALI dimmable drivers/ballasts communicate with the Lighting Control Panel over the DALI bus while the touchscreen communicates with the Central Manager via ethernet.

Complete Fifth Light system

