

<b>Project</b>		<b>Catalog #</b>		<b>Type</b>	
<b>Prepared by</b>		<b>Notes</b>		<b>Date</b>	



# Metalux

## 24GR LED

2' x 4' LED Troffer  
General Recessed LED Troffer  
For Use in Insulated Ceilings

### Typical Applications

- Office • Schools • Residential • Hospitals • Retail Merchandising Areas

### Product Certification



### Product Features



### Interactive Menu

- Order Information [page 2](#)
- Photometric Data [page 3](#)
- Control Solutions [page 5](#)
- VividTune™ Color Tuning Solutions [page 6](#)
- Product Warranty

### Top Product Features

- Available in 2' x 4', 2' x 2' and 1' x 4'
- Multiple lumen packages up to 18,000 in 2x4 and 9,000 in 2x2
- Up to 140 lm/W for maximum energy savings versus fluorescent troffers
- Correlated Color Temperatures 3000K, 3500K, 4000K and 5000K at 80 and 90 CRI
- Standard 0-10V continuous dimming driver
- Options to meet Build America, Buy America, Buy American and other domestic preference requirements

### Dimensional and Mounting Details

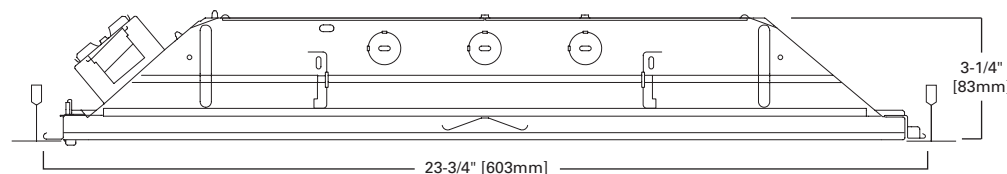

### Door Frames



### Mounting Data

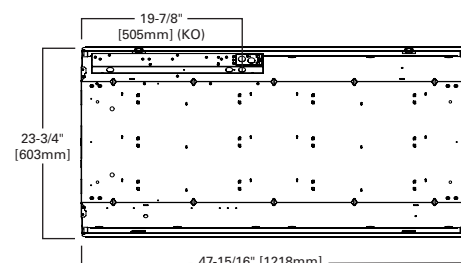

### Ceiling Compatibility

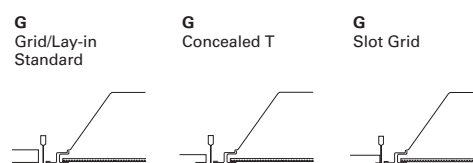

Ceiling Type	Trim Type
Exposed Grid	G
Concealed T	G
Slot Grid	G

(Verify compatibility/ consult factory.)

## Order Information SAMPLE ORDER NUMBER: 24GR-LD5-48-F1-UNV-L835-CD1-U

Domestic Preferences <sup>(1)</sup>	Rating	Width/Length	Trim Type	Series <sup>(3)</sup>	Door Frame	LED Type
<b>[Blank]</b> =Standard <b>BAA</b> =Buy American Act <b>TAA</b> =Trade Agreements Act <b>BABA</b> =Build America Buy America Act	<b>[Blank]</b> =Standard <b>ATW-SW4</b> =Chicago Rated	24=2' x 4'	<b>G</b> =Grid/Lay-in (Standard) <sup>(2)</sup> <b>G</b> =Concealed T <b>G</b> =Slot Grid	<b>R</b> =General Purpose Troffer	<b>Standard</b> =Flat White Steel Door (Leave Blank) <sup>(4)</sup> <b>FA</b> =Flush White Extruded Aluminum c/w Spring Latch <b>RA</b> =Regressed White Extruded Aluminum <b>FAN</b> =Flush Natural Anodized Extruded Aluminum <b>RAN</b> =Regressed Natural Anodized Extruded Aluminum <b>FAB</b> =Flush Black Extruded Aluminum <b>RAB</b> =Regressed Black Extruded Aluminum	<b>LD5</b> =LED 5.0
<b>Notes</b> (1) Only product configurations with these prefixes are built to be compliant with the Buy American Act of 1933 (BAA), Trade Agreements Act of 1979 (TAA), or the Build America Buy America Act (BABA). BABA is the minimum Government compliance requirement for the Build America Buy America standards which is part of the Infrastructure and Investment Jobs Act (IIJA). Individual Government Agencies may have more stringent compliance standards. Please refer to <a href="#">DOMESTIC PREFERENCES</a> website or consult the CLS Domestic Preferences team for more information. Components shipped separately may be separately analyzed under domestic preference requirements.			<b>Notes</b> (2) An EQ Grid Clip is recommended for all 9/16" ceiling systems.	<b>Notes</b> (3) DesignLights Consortium® Qualified and classified for DLC Standard, refer to <a href="#">www.designlights.org</a> for details.	<b>Notes</b> (4) Only Standard door frames can support wireguard accessory.	

LED Lumen Output <sup>(5)</sup>	Shielding	Voltage <sup>(11)</sup>	Options	Emergency	CCT
<b>30</b> =3000 <b>34</b> =3400 <b>38</b> =3800 <b>42</b> =4200 <b>48</b> =4800 <b>56</b> =5600 <b>64</b> =6400 <b>72</b> =7200 <sup>(6)</sup> <b>85</b> =8500 <sup>(7), (8)</sup> <b>90</b> =9000 <sup>(6), (8)</sup> <b>100</b> =10000 <sup>(6), (8)</sup> <b>120</b> =12000 <sup>(6), (8)</sup> <b>130</b> =13000 <sup>(6), (8)</sup> <b>150</b> =15000 <sup>(6), (8), (9)</sup> <b>180</b> =18000 <sup>(6), (8), (9)</sup>	<b>F1</b> =Pattern 12, Frosted Acrylic, 0.095" thick <b>F125</b> =Pattern 12, Frosted Acrylic, 0.125" thick <b>A</b> =Pattern 12, Clear Acrylic, 0.095" thick <b>A125</b> =Pattern 12, Clear Acrylic, 0.125" thick <b>A19/156</b> =Pattern 19, Clear Acrylic, 0.156" thick <sup>(10)</sup> <b>FGW080</b> =Frosted Smooth Acrylic, 0.080" thick <b>A/WG</b> =0.095" Pattern 12 Clear Acrylic Lens, with Wireguard directly below lens	<b>347V</b> =347 Volt <sup>(13)</sup> <b>UNV</b> =Universal Voltage 120-277 <sup>(12)</sup> <b>120V</b> =120 Volt <sup>(14)</sup> <b>277V</b> =277 Volt <sup>(14)</sup>	<b>GL</b> =Single Element Fuse <b>GM</b> =Double Element Fuse	<b>EL7W</b> =7-watt 120V-277V emergency battery pack <sup>(15)</sup> <b>EL10W</b> =10-watt 120V-277V emergency battery pack <sup>(15)</sup> <b>EL14W</b> =14-watt 120V-277V emergency battery pack <sup>(15)</sup> <b>EL10WSD</b> =10W emergency battery pack with self-diagnostic installed <sup>(15), (18)</sup> <b>EL14WSD</b> =14W emergency battery pack with self-diagnostic installed <sup>(15), (18)</sup> <b>GTR2</b> =Bodine Generator Transfer Relay <sup>(16), (17)</sup> <b>ETRD</b> =Emergency Transfer Relay with dimming control <sup>(14)</sup> <b>WNPS</b> =WaveLinX with Normal Power Sensing Beacon <sup>(19), (20), (21), (22)</sup> <b>WEM</b> =WaveLinX Enabled UL924 <sup>(19), (21), (22)</sup>	<b>L830</b> =3000K <b>L835</b> =3500K <b>L840</b> =4000K <b>L850</b> =5000K <b>L930</b> =90CRI, 3000K <b>L935</b> =90CRI, 3500K <b>L940</b> =90CRI, 4000K <b>L950</b> =90CRI, 5000K <b>L83050</b> =80CRI 3000K-5000K White Tuning <sup>(23)</sup> <b>L93050</b> =90CRI 3000K-5000K White Tuning <sup>(23)</sup> <b>L82765</b> =80CRI 2700K-6500K White Tuning <sup>(23)</sup> <b>L92765</b> =90CRI 2700K-6500K White Tuning <sup>(23)</sup>
<b>Notes</b> (5) Nominal lumen output. See table for actual values. (6) White tuning not available with this model. (7) The maximum lumens on this version with VividTune option will be 8300, see IES files for actual performance values. (8) Not compatible with WN driver. (9) XMRP required for 15000 lumens and up.	<b>Notes</b> (10) A19/156 lens creates holographic effect on the surface of the lens.	<b>Notes</b> (11) Products also available in non-US voltages and frequencies for international markets. (12) Not available when specifying emergencies, voltage must be specific. (13) 347V is not available with the W2A driver. (14) Must specify voltage as 120V or 277V when ordering GTR2 option.		<b>Notes</b> (15) Factory installed with integral test switch/indicator/laser test. For approximate delivered lumens multiply the lumens per watt of the desired fixture by the wattage of the emergency battery pack (100 lm/W x 7=700 lumens). IES-format photometry for luminaire under emergency operation available. Battery option increases total height by 1 inch. (16) Used to bypass local control during outage. Must be used in conjunction with UL 1008 device (provided by others). GTR2 option includes 2 relays on fixtures with dimming drivers. ETRD option only requires one relay when used on a dimming fixture. (17) Must specify voltage as 120V or 277V when ordering GTR2 option. (18) EL10WSD and EL14WSD not available with 347V. (19) Only available as part of a WaveLinX control system; must order with WLS or WPS sensor. Compatible with UNV CD drivers only. (20) WNPS is compatible with ESP-L or ESP-P emergency control devices. (21) Cannot be combined with other emergency, control or relay options. (22) For UL924 compliance, WEM and WNPS luminaires must be installed in the same application space.	<b>Notes</b> (23) White tuning provides correlated color temperatures (CCT) between 3000K (warm) to 5000K (cool) or 2700K (warm) to 6500K (cool). Must be used in conjunction with W2A.

Factory Wiring	Driver Type
<b>A3/8-4/18GDIM</b> =3/8" Flex with 0-10V Dimming Leads Multiple other configurations available. See below for details. <b>A3/8-5/18GDIM</b> =Flex with 0-10V Dimming leads and Blue for alternate wiring. See below for details.	<b>CD</b> =0-10V Driver (10%-100% Dimming) <sup>(24), (28), (29)</sup> <b>HCD</b> = 0-10V Driver (1%-100% Dimming) <sup>(26), (28), (29)</sup> <b>SLTD</b> =DALI Driver (5%-100% Dimming) <sup>(25)</sup> <b>SLTHD</b> =DALI Driver (1%-100% Dimming) <b>SD</b> =Step Dimming Driver (50% or 100% Dimming) <sup>(24)</sup> <b>LH</b> =Lutron HiLume (LDE1 series) 1%-100% EcoSystem Driver with Soft-on Fade to Black dimming <sup>(F)</sup> <b>WZA</b> =White Tuning, 2 ch, Intensity and CCT Control <sup>(27), (28)</sup> <b>SR</b> =Sensor-ready Driver (1%-100% Dimming)
<b>Flexible Metal Conduit Options</b> Flex options available for 0-10V dimming control, DALI dimming control, emergency and night light functions. 72-inch factory-installed and pre-wired to driver, fitted to luminaire housing access plate with 90° enclosed FMC connector. Not all options may be combined and installation ratings vary by type. <b>A3/8-4/18GDIM series notes:</b> Factory installed dimming option 3/8" flexible metal conduit with 2-#18 power and ground wires and 2-#18 UL-listed jacketed 0-10V +/- control wires. Meets UL 66, 83, 1479, 1559, 1581, 2556, NEC® 250.118, 300.22(C), 392, 396, 330, 501, 502, 503, 530, 504, 505, 518, 520, 530, 645, 72; Federal Specification A-A-59544 (formerly J-C-20B); all applicable OSHA and HUD Requirements. UL Classified 1-, 2-, and 3-hour through penetration with applicable fire stop product (not included). May be surface mounted, fished and/or embedded in plaster. Cable tray and approved raceway rated, install per NEC®; Environmental Air-Handling Space Installation per NEC® 300.22(C).	<b>Notes</b> (24) Step dimming (bi-level) 1 driver, 4200 - 10000, 2 driver, 12000 and up lumen model. (25) DALI available from 4200 - 9000 lumen models. Two drivers required for 10000 lumen models and up. (26) Requires two drivers for 10000 lumens and above. (27) White tuning provides correlated color temperatures (CCT) between 3000K (warm) to 5000K (cool) or 2700K (warm) to 6500K (cool). Must be used in conjunction with W2A. (28) WPS and WPN mode used with CD, HCD or W2A drivers only. (29) WLS and WLN mode used with CD or HCD drivers only. Integrated options must be used in conjunction with the associated system and may not be compatible with other options or accessories. Please refer to the following: (F) Consult Marketplace Options - Lutron system pages for additional details and compatibility. Compatible only with driver series shown, and may require two or more drivers. Requires field commissioning to operate or dim. Contact Lutron at <a href="#">www.lutron.com</a>

continued next page

## Order Information

CONTINUED

No. of Drivers	Options	Integrated Sensing Systems	Packaging	Accessories <sup>(65)</sup>
1=1 Driver 2=2 Drivers	<b>PAF</b> =Painted After Fabrication <b>G1</b> =Gasket, Door Frame and Housing <b>G2</b> =G1 plus Gasket between Lens and Door <b>G3</b> =G1 and G2 plus Gasketing on Mounting Surface of Fixture Trims <sup>(30), (31)</sup>	<b>[Blank]</b> =No Sensor <b>WLS</b> =WaveLinX LITE Integrated Sensor, Dim and Daylight, Bluetooth, 8'-15' MH <sup>(33), (B)</sup> <b>WPS</b> =WaveLinX PRO Integrated Sensor, Dim and Daylight, ZigBee, 8'-15' MH <sup>(32), (A)</sup> <b>WLN</b> =WaveLinX LITE Integrated Node, Dim and Daylight, Bluetooth <sup>(33), (B)</sup> <b>WPN</b> =WaveLinX PRO Integrated Node, Dim and Daylight, Zigbee <sup>(32), (A)</sup>	<b>U</b> =Unit Pack <b>PAL</b> =Job Pack, out of carton <b>PALC</b> =Job Pack, in carton	<b>EQ-CLIP-U</b> =T-BAR Safety Earthquake Clips <sup>(34)</sup> <b>DF-24W-U</b> =2' x 4' Drywall Frame Kit <b>SK-24-WS</b> =2' x 4' Shallow Surface Mount Kit <b>SK-24-WT</b> =2' x 4' Tall Surface Mount Kit
	<b>Notes</b> (30) Gasketing only available with aluminum door frame. (31) Gasketing minimum .125	<b>Notes</b> (32) WPS and WPN node used with CD, HCD or W2A drivers only. (33) WLS and WLN node used with CD or HCD drivers only.  Integrated options must be used in conjunction with the associated system and may not be compatible with other options or accessories. Please refer to the following: (A) Consult WaveLinX PRO system pages for additional details and compatibility. (B) Consult WaveLinX LITE system pages for additional details and compatibility.		<b>Notes</b> (34) An EQ Grid Clip is recommended for all 9/16" ceiling systems. (35) Accessories sold separately will be separately analyzed under domestic preference requirements. Consult factory for further information.

## Product Specifications

### Construction

- Rigid housing is die formed of code gauge prime cold rolled steel
- Full length die-formed stiffeners and unibody endplate for added strength
- Innovative design provides superior lens brightness, uniformity and visual comfort
- Unibody endplates are securely attached with interlocking tabs and screws
- Four auxiliary fixture end suspension points provided
- Endplates have integral Grid-lock feature for safety and convenience

### Controls

- Standard with 0-10V dimming driver (10% standard, 1% optional)
- Integrated WaveLinX options provide wireless individual fixture control and enable code compliance, increased energy savings, grouping of fixtures, and connection to WaveLinX control systems
- DALI 2.0, Lutron, and step-dimming available

### Electrical

- TM-21 life at 60,000 hours up to L88 and calculated L70 exceeds 162,000 hrs.
- Available in 3000K, 3500K, 4000K or 5000K with a minimum of 80 CRI
- Color accuracy  $\leq 3$ -Step MacAdam ellipse (SDCM)
- Drivers available in 120-277V and 347V
- Tunable white options available with Cooper Lighting Solutions' VividTune

### Emergency Battery Pack Option

- 120V-277V integral emergency battery pack comes in 7-watts, 10-watt, or 14-watts
- Self-diagnostic emergency battery available in 10 or 14-watts (NFPA 101@ Life Safety Code®)
- Constant power to the LED system for controlled, predictable discharge
- Integrated test switch/indicator light visible from floor
- Min. 90-minute backup period for code compliance
- Integral emergency transfer relay available for generator equipped power systems

### WNPS - WaveLinX Normal Power Sensing

- Normal Power Sensing (NPS) wireless beacon enabled luminaire that signals normal power is present
- Must be ordered with WaveLinX LITE or PRO sensor as part of a WaveLinX control system
- For UL924 compliance, WNPS enabled luminaires with standard product and compatible emergency control devices (ESP-P/ESP-L) must be installed in same application space

### WEM - WaveLinX UL924 Emergency Sensor

- Emergency control devices (ESP-P/ESP-L) not required when WEM and WNPS luminaires are installed in the same application space
- For UL924 compliance, order WEM and WNPS luminaires in the same application space
- WEM must be ordered with WLS or WPS sensor as part of a WaveLinX control system

### Frame/Optical Shielding

- Die formed, flat steel door with frosted #12 pattern acrylic prismatic lens
- Primary stocking skus come standard with robust .095 lens
- Other options available for maximum versatility
- Replacement lenses available, contact factory

### Compliance

- IC rated for insulation contact
- cULus listed for damp locations
- RoHS compliant
- Tested to IESNA LM-79 and LM-80
- Stated life per TM21 standards
- Can be used for State of California Title 24 high efficacy luminaire

### BABA Domestic Preference Compliance

- This Cooper product is manufactured in the US and meets the BABA cost of components rule. To verify a configured product with specific accessories and options meets BABA Domestic Preference Requirements; submit this catalog number to Cooper Lighting Quotation team for validation by our Engineering and Manufacturing teams. Our BABA designation is based on the minimum compliance requirement for BABA. Individual Government Agencies may have more stringent compliance standards. Please refer to the [DOMESTIC PREFERENCES](#) website or consult the CLS Domestic Preferences team for more information. Components shipped separately may be separately analyzed under domestic preference requirements.

## Photometric Data

 View IES files

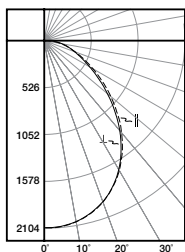

### 24GR-LD5-48-F1UNV-L835-CD1-U

Electronic Driver  
Linear LED 3500K  
Spacing criterion: (H) 1.19 x mounting height,  
(L) 1.18 x mounting height  
Lumens: 4821  
Input Watts: 37W  
Efficacy: 128.6 lm/W  
Test Report: 24GRLD5-48-F1-UNVL835-CD1-U.IES

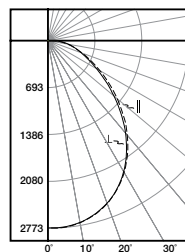

### 24GR-LD5-64-F1UNV-L835-CD1-U

Electronic Driver  
Linear LED 3500K  
Spacing criterion: (H) 1.19 x mounting height,  
(L) 1.18 x mounting height  
Lumens: 6462  
Input Watts: 48W  
Efficacy: 134.2 lm/W  
Test Report: 24GRLD5-64-F1-UNVL835-CD1-U.IES

## Energy and Performance Data

Stock or MTO*	Catalog Logic	Delivered Lumens	Watts	Efficacy (lm/W)
MTO	24GR-LD5-30-F1-UNV-L835-CD1-U	3074	23.4	131
MTO	24GR-LD5-34-F1-UNV-L835-CD1-U	3459	26.7	129
Stock	24GR-LD5-38-F1-UNV-L835-CD1-U	3880	30.6	127
MTO	24GR-LD5-42-F1-UNV-L835-CD1-U	4294	34.6	124
Stock	24GR-LD5-48-F1-UNV-L835-CD1-U	4821	37.4	129
MTO	24GR-LD5-56-F1-UNV-L835-CD1-U	5618	45.1	124
Stock	24GR-LD5-64-F1-UNV-L835-CD1-U	6462	48.1	134
MTO	24GR-LD5-72-F1-UNV-L835-CD1-U	7257	56.0	129
MTO	24GR-LD5-85-F1-UNV-L835-CD1-U	8567	70.3	122
MTO	24GR-LD5-90-F1-UNV-L835-CD1-U	9092	69.1	132
MTO	24GR-LD5-100-F1-UNV-L835-CD2-U	10030	71.7	140
MTO	24GR-LD5-120-F1-UNV-L835-CD2-U	12260	90.1	136
MTO	24GR-LD5-130-F1-UNV-L835-CD2-U	13290	90.2	134
MTO	24GR-LD5-150-F1-UNV-L835-CD2-U	15340	120.3	128
MTO	24GR-LD5-180-F1-UNV-L835-CD2-U	18050	144.2	125

\*Stocked in 3500K and 4000K others are MTO.

### Lumen Maintenance

Ambient Temperature	TM-21 Lumen Maintenance (60,000 hours)	Theoretical L70 (Hours)
25°C	> 88%	> 162,000

### Lens Table

Approximate Lumen Multiplier	
F1	1.0
F125	1.0
A125	1.01
A	1.01
A19/156	.975
FGW080	.85

### CCT Table

Approximate Color Temperature Multiplier	
5000K	1.016
4000K	1.016
3500K	1.0
3000K	.982
2700K	.930

### Shipping Data

Catalog No.	Wt.	Pallet
24GR-LD5-48	20 lbs.	28

## Control Solutions

- WaveLinX LITE wireless
- WaveLinX PRO wireless
- WaveLinX CAT wired
- WaveLinX DALI wired



The GRLED with WaveLinX offers no-hassle lighting control with multiple luminaire level control solutions.

**WaveLinX** by Cooper Lighting Solutions is a wired and wireless solution for a single room, a parking lot, or an entire campus, helping meet energy codes, reduce energy use, and create healthier environments. As a true hybrid architecture, it enables the seamless integration of DALI, CAT, and PRO technologies and luminaires for unmatched reliability and flexibility, with sensor-enabled luminaires that can also share data with the WaveLinX CORE platform, further improving operations across office, education, healthcare, warehouse, and parking garage applications.



**WaveLinX LITE** is a Bluetooth wireless digital lighting control solution with out-of-the-box functionality that saves energy and meets energy codes. It's designed for applications that require occupancy-based, daylighting, or manual light control using WaveLinX LITE-enabled luminaires and a mobile app for cost-effective projects.



**WaveLinX PRO** is a Zigbee wireless solution that offers a rich portfolio of devices, WaveLinX PRO-enabled luminaires, and a mobile app and the WAC (WaveLinX Area Controller). It offers advanced energy savings and deep data integration to improve the occupant experience.



**WaveLinX CAT** is a scalable CAT5-wired solution for a single room and connected spaces, supporting applications that require occupancy-based, daylighting, or manual light control, with self-commissioning to meet energy codes and maximize energy savings.



**WaveLinX DALI** is a powerful two-wire DALI-2 solution for connected spaces, combining open-standard devices enabling interoperability with the simplicity of WaveLinX app-based commissioning. It delivers deterministic wired control, granular addressability, and tunable white.

### Integrated Sensor Coverage Pattern

TOP VIEW:

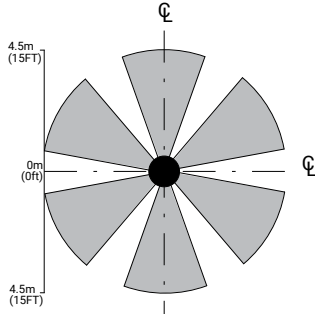

SIDE VIEW:

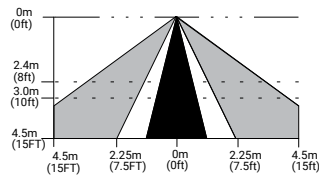

**Note:** Installation of integrated sensors within 3-ft (1m) of HVAC air vents is not recommended. The pattern shown is intended solely as a general guide and is not to scale.

**With Integrated WaveLinX Sensor**

**With Integrated WaveLinX Node**

**Add a hidden WaveLinX Node (WPN, WLN) to your space lighting design!**

**To:**

- Keep luminaire aesthetics
- Connect fixtures without space for a sensor, such as downlights
- Connect sealed fixtures without a standard sensor option such as products for clinical space

### Integrated Controls Options

Option	Out of the Box Functionality	Luminaire Level Lighting Control (LLLC)	Automatic Dimming Photocell	Occupancy Sensing	CCT Control*
WLS (WaveLinX LITE Sensor)	X	X	X	X	
WLN (WaveLinX LITE Node)		X			
WPS (WaveLinX PRO Sensor)		X	X	X	X
WPN (WaveLinX PRO Node)		X			X

**Note:** \*WaveLinX utilizes scenes to allow users to change an area's fixtures Correlated Color Temperature (CCT) and intensity using a commissioned wireless wallstation scene controller. To enable CCT adjustments through WaveLinX, include WPS or WPN devices in addition to VividTune or BioUp technologies for integrated fixture control. WPS with CCT controls the intensity of the fixture; an additional, externally mounted control device is needed to control the CCT. See [RSP-P-010-347](#)

The WNPS and WEM (UL924 option) only available with WLS or WPS sensors. Must be specified when ordered. WEM must be associated with a group that includes a normal power sensing device to receive NPS beacon. Learn more about WaveLinX EM [here](#).

### WaveLinX EM

The WaveLinX Emergency (WEM) solution offered by WaveLinX wireless (PRO and LITE) makes it easy to design your UL924 certified emergency lighting solution. Fixture-integrated WaveLinX Emergency Modules (WEM) override lighting controls and increases light output to emergency level (100%) until normal power is restored. Needs programming. WaveLinX emergency systems are designed to meet UL 924 standards. Learn more [here](#).

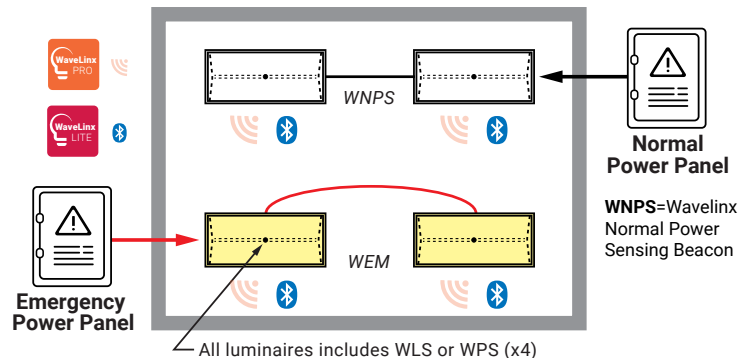
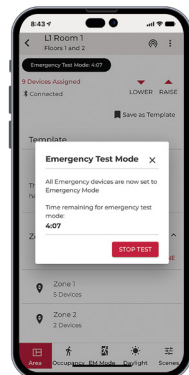



### 24GR LED with VividTune Tunable White

VividTune tunable white luminaires from Cooper Lighting Solutions deliver high-quality light in a broad range of continuously variable color temperatures and intensities. Create a dynamic environment by adjusting the ambient light warmer or cooler to influence mood, support the task at hand, or create a dramatic ambience. The ability to control correlated color temperature and intensity separately using simple controls is the next evolution of LED lighting for the commercial, educational, healthcare and hospitality space. The unparalleled flexibility and number of available lighting environments enable users to find the right light with tunable white.

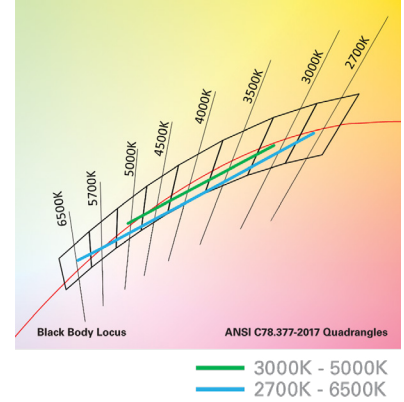

### Performance Data\*

Tunable White - Lumen Adjustment Factors (example only)				
CCT	3000K-5000K		2700K-6500K	
	80 CRI	90 CRI	80 CRI	90 CRI
2700K	-	-	0.923	0.789
3000K	0.950	0.783	0.949	0.820
3500K	1.006	0.855	0.983	0.861
4000K	1.056	0.923	1.004	0.888
4500K	1.066	0.939	1.022	0.911
5000K	1.066	0.939	1.036	0.929
6500K	-	-	1.051	0.955

2' x 4' GRLED - Example of Approximate Lumen Calculation			
	Standard Catalog #	VividTune 80 CRI Catalog #	VividTune 90 CRI Catalog #
CCT Setting	24GR-LD5-48-F1-UNV-L835-CD1-U	24GR-LD5-48-F1-UNV-L83050-W2A1-U	24GR-LD5-48-F1-UNV-L93050-W2A1-U
3000K	-	4582	3773
3500K	4821	4849	4122
4000K	-	5091	4451
4500K	-	5140	4529
5000K	-	5140	4529

### Controlling VividTune Tunable White

VividTune luminaires make tunable white more accessible by using simple and familiar controls. From wall dimmers to wireless controls, VividTune tunable white luminaires are compatible with industry standard 0-10V dimming controls. A single 0-10V dimming input is used to control intensity (brightness) while a second 0-10V dimming input is used to adjust CCT. For suggested control configurations, go to [www.cooperlighting.com](http://www.cooperlighting.com) for tunable white application guides.

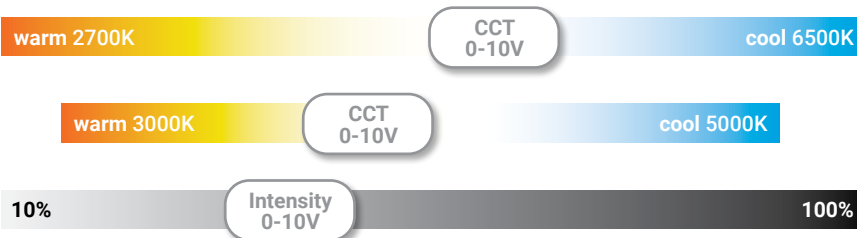

### Example of Lumen Adjustment Calculation

**24GR-LD5-48-F1-UNV-L83050-W2A1-U**  
at 80 CRI tuned to 3500K

*Adjusted Lumen = published lm x adjusted lm factor*

*Adjusted Lumen = 4821 x 1.006*

*Adjusted Lumen = 4849 lm*

\* Lumen adjustment factors are for reference and may be different for each product selected. Refer to IES files for actual performance data on each.