

Project		Catalog #		Type	
Prepared by		Notes		Date	

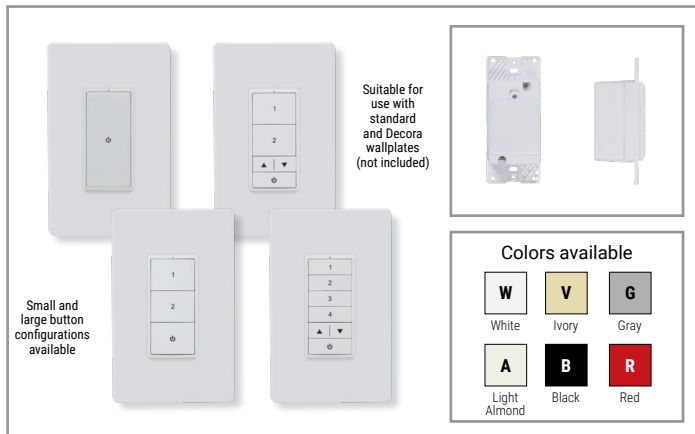

## WaveLinX

### PRO Battery-Powered Wallstation (WWB-Series) and colored wallstations (WST series)

Multi-scene dimming battery-powered wallstation which provides customized light level for each area

#### Typical Applications

Office • Education • Hospitality • Retail • Industrial • Manufacturing

**Interactive Menu**

- Order Information page 2
- Button Options page 2
- Additional Resources page 3
- Product Warranty



- Meets latest ASHRAE Standard 90.1 requirements
- Meets latest IECC requirements
- Meets latest CEC Title 24 requirements

#### Product Features



#### Compatibility



### Overview

The PRO Wallstation is an integral part of the WaveLinX connected lighting system and is available in several small and large button configurations in white color. These wallstations are battery-powered and provide wireless control of the lighting in each area.

The wallstation mounts to a low-voltage wall box (single or multi-gang) and is suitable for a standard or decorator wallplate (not included). Each wallstation is fully configurable to provide local and multi-level control in each area. Each button is configured to control a lighting scene for an area and can be modified using the WaveLinX Mobile Application.

The wallstation is a multi-scene, single area dimming wallstation which provides customized light level for each area. The wallstation provides default operations, but is fully configurable from the WaveLinX Mobile Application. Two wallstation configurations also include scene raise / lower buttons to further adjust the light levels.

### Product Features & Benefits

- Standard settings, multi-scene selection, raise/lower, on/off toggle for an area
- Suitable for standard single or multi-gang NEMA wall box
- Utilizes two (2) CR123A alkaline batteries for simple new or retrofit installations
- Clean, elegant and simple control
- 5 Color options available
- Configurable through the WaveLinX Mobile Application

## Order Information

All WaveLinx PRO control devices require at least one WaveLinx Area Controller for communications. Please ensure that you order a WaveLinx Area Controller (CATNO: WAC2-POE) for the product to work or connect the wallstations to an existing WaveLinx Area Controller. **Important Note:** The WaveLinx wallstation only works with version 12+ of the 2nd generation WaveLinx Area Controller (WAC2-POE). It does not work with the 1st generation WaveLinx Area Controller (WAC-POE).

SAMPLE ORDER NUMBER: **WST-P-3D-R-BP** (Wavelinx PRO, 3 Button Dimming, Red, Battery Powered)



Catalog Number

## Standard Wallstation Configurations

Catalog Number	Description
<b>WWB1-W</b>	WaveLinx PRO Battery-powered Wallstation, 1 Button, White
<b>WWB3-W</b>	WaveLinx PRO Battery-powered Wallstation, 3 Button, White
<b>WWB3-RL-W</b>	WaveLinx PRO Battery-powered Wallstation, 3 Button Raise / Lower, White
<b>WWB5-RL-W</b>	WaveLinx PRO Battery-powered Wallstation, 5 Button Raise / Lower, White
<b>Notes</b>	<b>Notes</b>
WaveLinx mobile application required to customize programming for each button.	Suitable for use with standard decorator wall plates (not included). Complete wallstation - buttons are not field replaceable.

## Custom Engraved Wallstation Configurations

Catalog Number	Description
<b>WWB1-W-ENGRV</b>	WaveLinx PRO Battery-powered Wallstation, 1 Button, White, Custom Engraved
<b>WWB3-W-ENGRV</b>	WaveLinx PRO Battery-powered Wallstation, 3 Button, White, Custom Engraved
<b>WWB3-RL-W-ENGRV</b>	WaveLinx PRO Battery-powered Wallstation, 3 Button Raise / Lower, White, Custom Engraved
<b>WWB5-RL-W-ENGRV</b>	WaveLinx PRO Battery-powered Wallstation, 5 Button Raise / Lower, White, Custom Engraved
<b>Notes</b>	<b>Notes</b>
WaveLinx mobile application required to customize programming for each button.	Suitable for use with standard decorator wall plates (not included). For custom engraving use the configurator tool within the FlashPro Program (CUST-ENGRV). Complete wallstation - buttons are not field replaceable.

## Colored Wallstation Configurations

Product	System Type	Button Configuration	Color	Power Supply	Custom Engraving
<b>WST</b> = Wallstation	<b>P</b> = PRO	<b>1</b> = 1 Button <b>3</b> = 3 Button <b>3D</b> = 3 Button Dimming <b>5D</b> = 5 Button Dimming	<b>V</b> = Ivory <b>G</b> = Gray <b>A</b> = Light Almond <b>B</b> = Black <b>R</b> = Red	<b>BP</b> = Battery Powered	<b>ENGRV</b> = Custom Engraved
<b>Notes</b>					<b>Notes</b>
WaveLinx mobile application required to customize programming for each button. Suitable for use with standard and Decora wallplates (not included). Buttons are not field replaceable.					For configuring Custom Engraved wall stations, please use <a href="#">Configurable Spec Sheet</a> .

## Additional Accessories

Wallplates are not included with Wallstations. Please order separately.

Catalog Number

Catalog Number	Description
<b>PJS26W</b>	1 Gang Screwless Faceplate, White
<b>PJS262W</b>	2 Gang Screwless Faceplate, White
<b>PJS263W</b>	3 Gang Screwless Faceplate, White
<b>PJS264W</b>	4 Gang Screwless Faceplate, White
<b>PJS265W</b>	5 Gang Screwless Faceplate, White

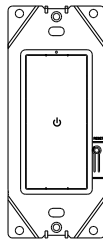

WWB1-W

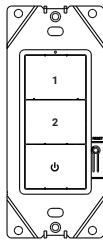

WWB3-W

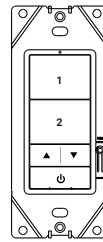

WWB3-RL-W

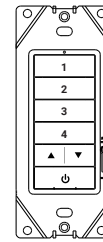

WWB5-RL-W

Standard button engraving for each wallstation

#### Default engraving & light levels

<b>Button 1</b>	Scene 3 = 50%
<b>Button 2</b>	Scene 1 = 100%
<b>Button 3</b>	Scene 2 = 70%
<b>Button 4</b>	Scene 4 = 30%
<b>Raise press*</b>	Increase 1% (per press)
<b>hold*</b>	Increase 15% (per sec)
<b>Lower press*</b>	Decrease 1% (per press)
<b>hold*</b>	Decrease 15% (per sec)
<b>Power*</b>	Toggle Scene 3 (50%) & Scene 0 (Off)

\* - affects last button press (OR last selected) command within the area

#### Raise / Lower / OFF buttons

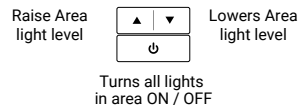

#### Button programming options via WaveLinx Mobile Application

Scene Selection
Zone Level
Raise Level
Lower Level
Toggle Scene or Zone Level
No Action

## Product Specifications

### Mechanical

**Size:** 4.2"H x 1.8"W x 1.5"D (107mm x 45mm x 39mm)

#### Environment:

- **Operating temperature:** 32°F to 113°F (0°C to 45°C)
- **Storage temperature:** 32°F to 167°F (0°C to 75°C)
- **Relative humidity operating:** 5% to 95% non-condensing
- For indoor use only

**Mounting:** Standard single or multi-gang NEMA wall box, and compatible with a decorator wall plate (not included)

**Colors:** White, Ivory, Gray, Light Almond, Black and Red

### Electrical

**Power supply type:** Utilizes two (2) CR123A alkaline batteries (included)

### Hardware Specifications

#### Status Indicators:

- Single indicator LED
- LED functionality (active for 3 seconds after action)
  - Indication of wireless network join request
  - Indication of wireless network connection
  - Scene indication of operations

#### Button Configuration:

- 1 Button
- 3 Button
- 3 Button with Raise / Lower
- 5 Button with Raise / Lower

### Software Specifications

- Each button programmable to trigger or toggle Scene or Zone
- Default values when joined to an area via WaveLinx Mobile application
- Models available with dominant button 50% light level
- Fade rates and scene transitions are programmable

### Wireless Specifications

**Radio:** 2.4GHz

**Standard:** IEEE 802.15.4

**Transmitter Power:** + 7dBm

**Configuration type:** Router, End Point

**Range:** 100ft (30m) LOS through 2 interior walls of standard construction

Note: Use of metallic wall plates is not recommended as they may interfere with the wireless signals

### System Performance

**Maximum number of Devices:** 200 per WaveLinx Area Controller (best practice 150 devices)

### Standards/Ratings\*

- FCC Part 15, Subpart B & C
- Meets latest ASHRAE Standard 90.1 requirements
- Meets latest IECC requirements
- Meets latest CEC Title 24 requirements
- NEMA WD-7 and NEMA 4 compliant
- CA Title 20 and Prop 65 compliant
- RoHS

### Warning

- This product is not intended to be used in applications involving the use of ammonia-based or VOC cleaners.
- Use of ammonia-based or VOC cleaners on this device must be avoided. Prolonged use may cause loss of integrity and expose electrified components. If this occurs, turn OFF power to the unit and replace.
- For detailed cleaning guidelines please refer to: Controls Care and Maintenance instructions at the end of this document.

### Warranty

Five year warranty standard



Download the WaveLinx Mobile App from either the Google Play or Apple Store®

## Dimensional Details

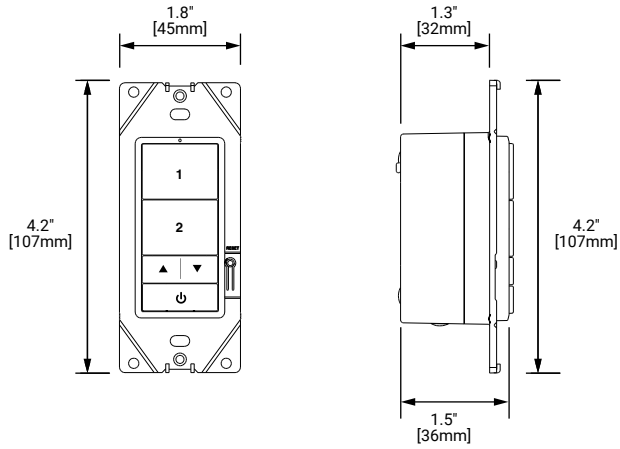

## Mounting Height

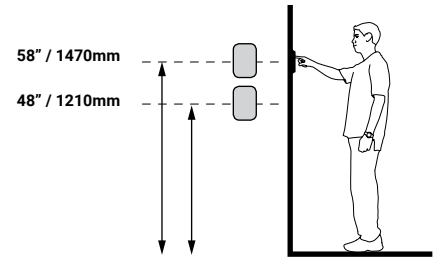

## Installation

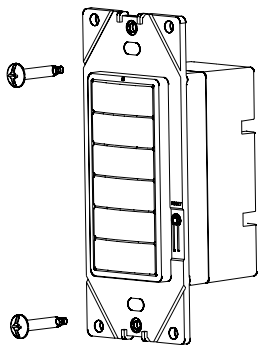

Wall plate not included

## System Diagram:

This diagram shows the main components of the WaveLinx connected lighting system with WaveLinx DALI, CAT and PRO devices. The PRO devices communicate using wireless mesh technology based on the IEEE 802.15.4 standard. A PoE LAN connection for each WaveLinx Area Controller (WAC) is required for power and data access to the building lighting network. The CAT devices communicate over the category 5 based communication bus and control the light fixtures using a relay (on/off) and 0-10V output (dim/raise). WaveLinx DALI devices communicate via a DALI bus (2 wires), which connects various components including DALI fixtures, a DALI DAC (DALI to 0-10V converter), DALI field relays, DALI wallstations, and DALI occupancy sensors. WaveLinx Area Controllers (WAC) communicate with WaveLinx CORE Apps over the Ethernet network.

[View WaveLinx Network and IT Guidance Technical Guide](#)

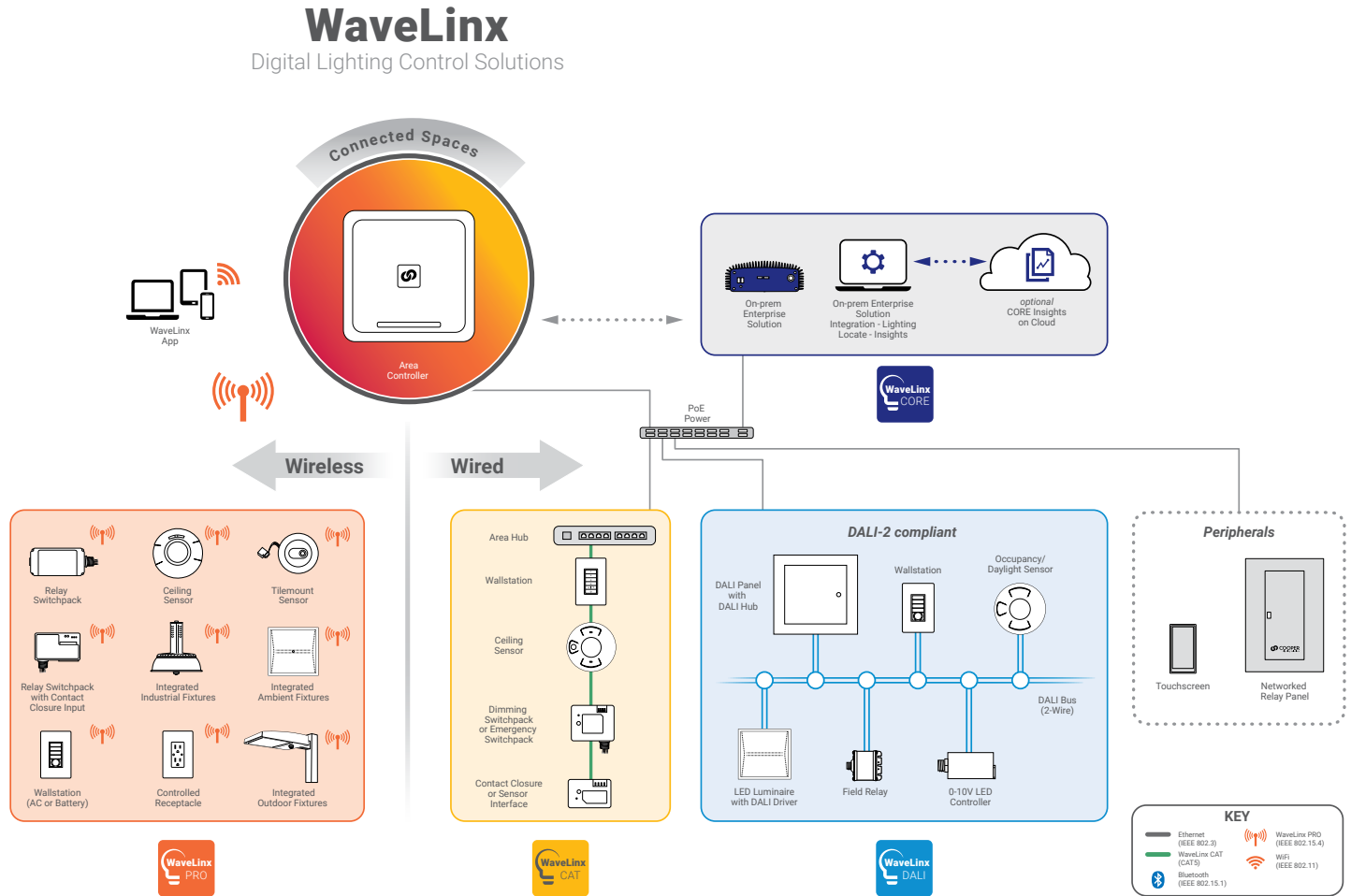

**Control Systems**  
• WaveLinx



Cooper Lighting Solutions has developed recommended guidelines for cleaning our products that will not impact the operation or finish of the product.

### Recommended cleaning tips:

- **Never spray any fluids directly into the device.**
- **Use of ammonia-based or VOC cleaners on this device must be avoided.** Prolonged use may cause loss of integrity and expose electrified components. If this occurs, turn OFF power to the unit and replace.
- **Use a damp rag or single-use wipe** to avoid excess liquid penetrating the device.
- Be sure to wipe up remaining excess liquid after cleaning.
- Ensure the cleaning agent used does not have harsh chemicals such as bleach, ammonia, highly alkaline or concentrated acids (such as hydrochloric acid that can be found in household cleaners such as toilet bowl cleaners, bathroom tile and porcelain cleaners) as they could damage the device, causing them to become brittle and discolored.
- Cooper Lighting Solutions recommends the use of a mild liquid detergent and water to clean the devices. Single use wipes (e.g. Lysol brand or equivalent) are acceptable to use for cleaning the devices, however the single-use wipes **cannot contain bleach, ammonia, highly alkaline or concentrated acids.**

### Recommended cleaning instructions:

- **Never spray any fluids directly into the device.**
- Apply the mild liquid detergent to a damp cloth or paper towel. Single use wipes (e.g. Lysol brand or equivalent) are acceptable to use for cleaning the devices, however single-use wipes cannot contain bleach, ammonia, highly alkaline or concentrated acids.
- If excess liquid is present, remove by wringing out the cloth or paper towel to avoid liquid penetration into the device.
- Clean the Cooper Lighting Solutions device by wiping over the surface with the damp cloth.
- Remove an excess liquid remaining on the device with a dry cloth or paper towel.

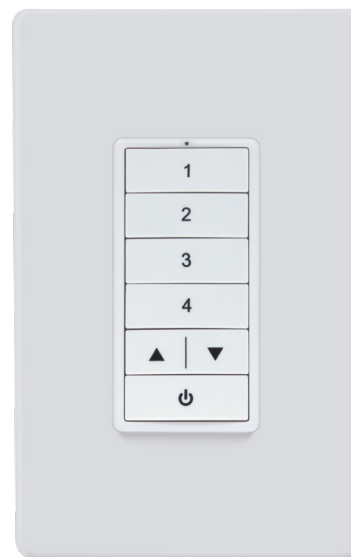

image for reference only

### **WARNING**

***This product is not intended for use in applications involving the use of ammonia-based or VOC cleaners.***

***Prolonged use may cause loss of integrity and expose electrified components.***

***If this occurs, turn OFF power to the unit and replace.***