



VXB
VISION BOLLARD

35 - 100 W

Metal Halide

High Pressure Sodium

26 - 42 W

Compact Fluorescent

LOW LEVEL LUMINAIRE

- Vandal resistant low copper, die-cast aluminum top
- Heavy wall seamless extruded aluminum shaft. Optional button photocontrol mounts to extrusion
- Standard impact and UV resistant injection molded acrylic lens
- Continuous silicone gasketing provided between extruded housing and lens to forbid entry of contaminants
- Glare-free, fully concealed reflector system features a high efficiency fluted hydroformed reflector for superior light output and uniform pavement illumination
- Quick-disconnect ballast assembly located at base of housing for cooler operation and ease of maintenance
- Medium-base porcelain socket for HID lamp sources
- Rugged cast aluminum base features two (2) factory installed leveling vials
- Approximate net weight: 32 lbs. (14.5 kgs.)

DESCRIPTION

The Vision Bollard from INVUE brings architectural style to the pedestrian level. The Vision Bollard can be used along with Vision Series' Area, Flood, and Wall luminaires to provide a coordinated look sure to enhance any architectural setting. Concealed lamp and reflector system eliminates all visible glare while providing high levels of pavement illumination. U.L. listed and CSA certified for wet locations.



DIMENSIONS

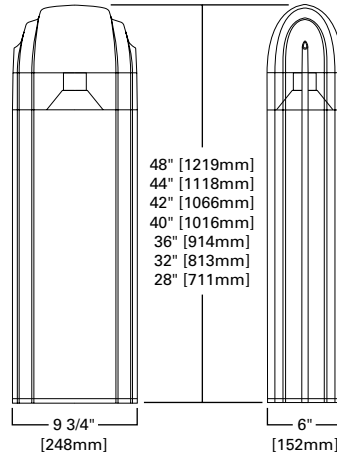

ORDERING INFORMATION

SAMPLE NUMBER: VXB-40-70-MH-MT-BK

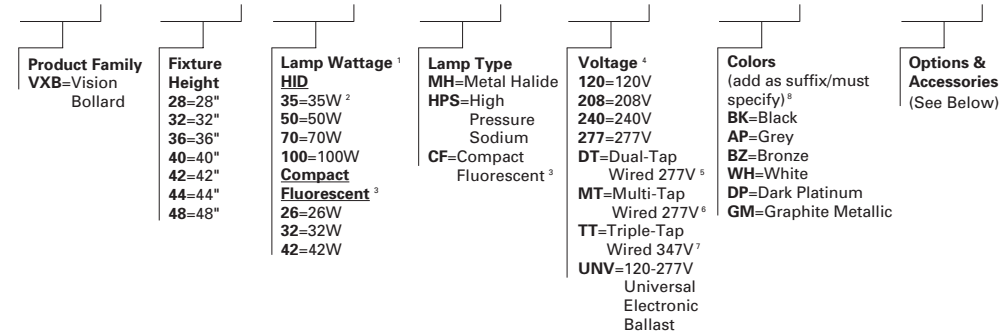

Options ⁹
F=Single Fuse (120, 277 or 347V)
 Specify Voltage
FF=Double Fuse (208 or 240V)
 Specify Voltage
PL=Polycarbonate Lens
PC=Button Type Photocontrol
 (Specify Voltage)
CF/EM=Compact Fluorescent ¹⁰
 Emergency Battery Pack
L=Lamp Included ¹¹

Accessories ¹²
VXBABKIT=Anchor Bolt Kit

Certifications

IP44 Rated	U.L. 1598 Listed		CO Cutoff
CSA Listed	25°C Ambient	ISO 9001	

WATTAGE TABLE	VXB
Metal Halide	50, 70, 100W
High Pressure Sodium	35, 50, 70, 100W
Compact Fluorescent	26, 32, 42W

NOTES: 1 All lamps are medium-base. 2 35W HPS available in 120V only. 3 CF lamps use electronic ballast 120-277V (UNV) only. 4 Products also available in non-US voltages and 50Hz for international markets. Consult factory for availability and ordering information. 5 Dual-Tap is 120/277V wired 277V. 6 Multi-Tap ballast is 120/208/240/277V wired 277V. 7 Triple-Tap ballast is 120/277/347V wired 347V. 8 RAL and custom color matches available. Consult your INVUE Lighting Systems Representative for more information. 9 Add suffix in the order shown. 10 CF lamps only. Battery backup operates 90 minutes at minimum 32°F (0°C), 42W maximum. 11 Coated lamp recommended. 12 Order separately, replace XX with color suffix. 13 Specifications and dimensions subject to change without notice.